

REVISIONS				
REV.	DESCRIPTION	ECO #	DATE	APPROVED
A1	RELEASE	2014-451	10/10/2014	CUB

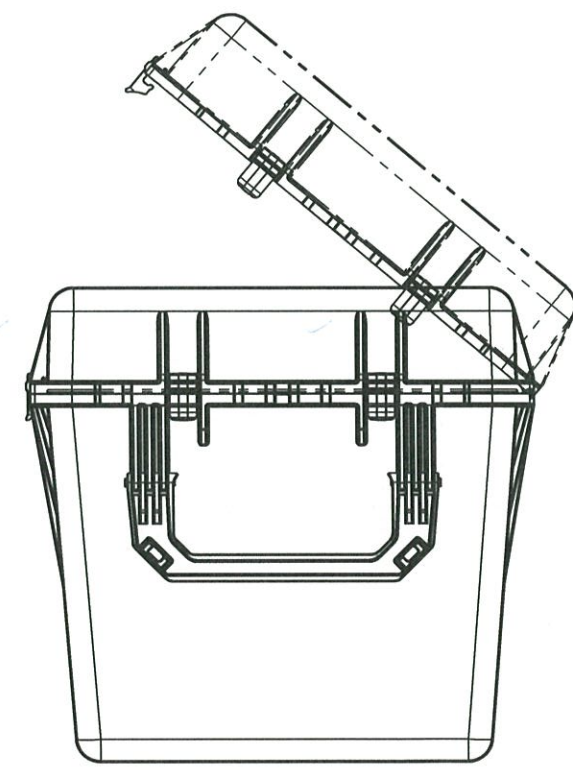
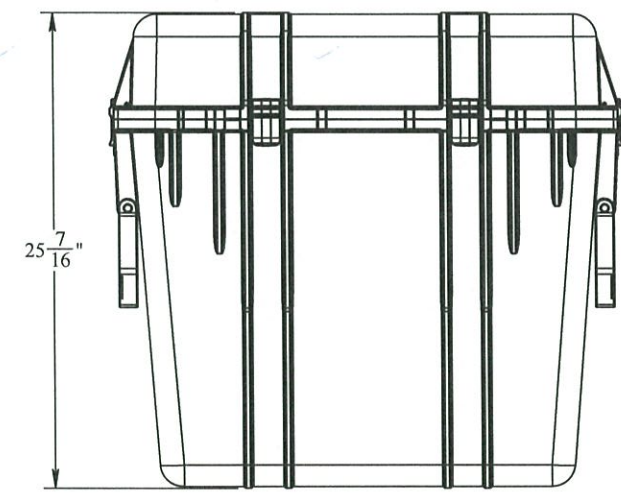
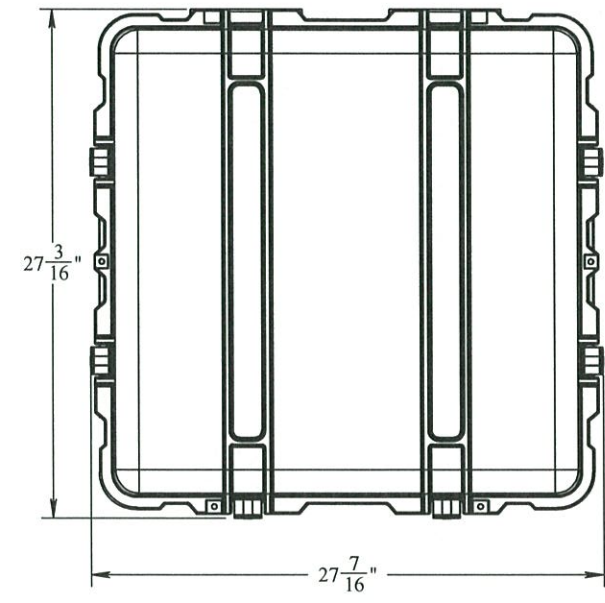

**CASE FEATURES**

1. CONVENIENT SHIPPING & STORAGE CONTAINER FOR DRIFT.
2. DESIGNED SPECIFICALLY FOR THE 18-3/4" x 23" DRIFT.
3. INTERNAL 4 LB. FOAM STRUCTURE PREFIT FOR THE DRIFT.
4. POCKETS FOR DATABOOK & OIL BOTTLE.
5. INCLUDES SET OF 4 CASTERS.

**PROPRIETARY AND CONFIDENTIAL:**  
 THE INFORMATION CONTAINED IN THIS DRAWING IS THE SOLE PROPERTY OF THE SUBSEA COMPANY INC. ANY REPRODUCTION IN PART OR AS A WHOLE WITHOUT THE WRITTEN PERMISSION OF THE SUBSEA COMPANY INC IS PROHIBITED.

WORKMANSHIP STANDARD PER WI 751-001

UNLESS OTHERWISE SPECIFIED: ALL DIMENSIONS ARE IN INCHES

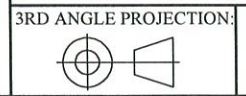

INTERPRET GEOMETRIC TOLERANCING PER: ASME Y14.5

	NAME	DATE
DRAWN	G. DEB	10-10-14
CHECKED	W. DEB	10-13-14
Q.A.	CUB	10-21-14
MFG./SALES	T. DEB	10-13-14



THE SUBSEA COMPANY INC

SIZE	TITLE:	REV
B	DRIFT, CASE, 18 3/4" API, 23" WITH PAD EYES	A1

DWG. NO. TSC-02108-GA

SHEET 1 OF 1