

REVISIONS				
REV.	DESCRIPTION	ECO #	DATE	APPROVED
C1	ADDED TABLES FOR SPARE AND REPAIR PARTS KITS	2014-488	11/19/14	<i>CMB</i>

TSC-01179-SK SPARES, KIT, VACUUM PUMP ASSEMBLY WITH CASE, 10 CFM		
PART NUMBER	DESCRIPTION	QTY.
SE-01235	OIL, VACUUM PUMP, QUART BOTTLE	1
TSC-01393	POWER CORD, WITH VELCRO STRAP, VACUUM SYSTEM	1
SE-0968	HOSE, 20' RED STANDARD IN-LINE BALL VALVE HOSE, CPS	2
SE-1010	CAP, 1/4" SAE, PLASTIC, W/STRAP	6
SE-1213	UNION, 1/4" JIC MALE X 1/4" JIC MALE, 316SS	2

TSC-01179-RK REPAIR, KIT, VACUUM PUMP ASSEMBLY WITH CASE, 10 CFM		
PART NUMBER	DESCRIPTION	QTY.
TSC-01179-SK	SPARES, KIT, VACUUM PUMP ASSEMBLY WITH CASE, 10 CFM	1
TSC-01181	VACUUM GAUGE MANIFOLD ASSEMBLY, 0-30"Hg,	1
SE-0887	PUMP, VACUUM, 10 CFM, 110/220 VAC	1

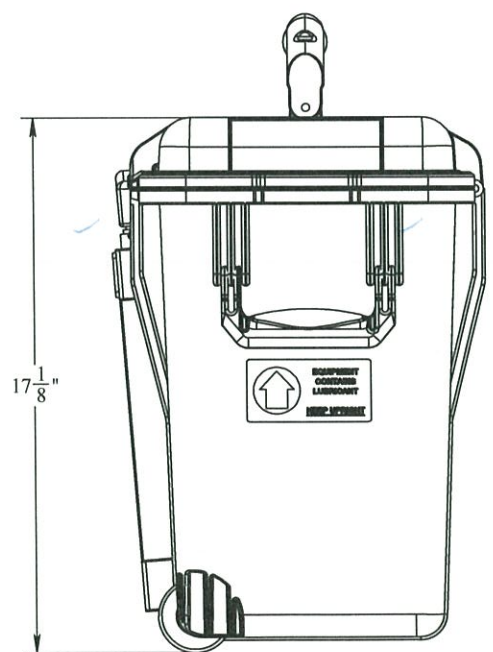
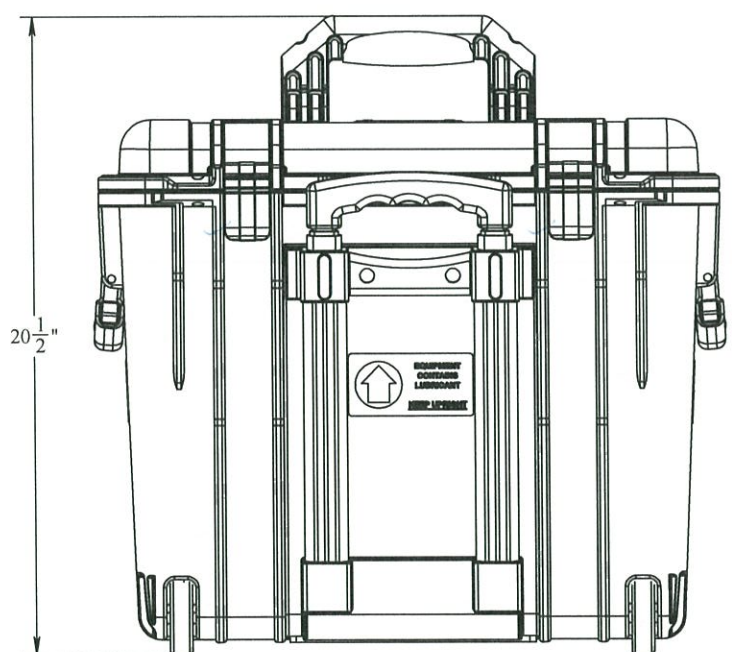
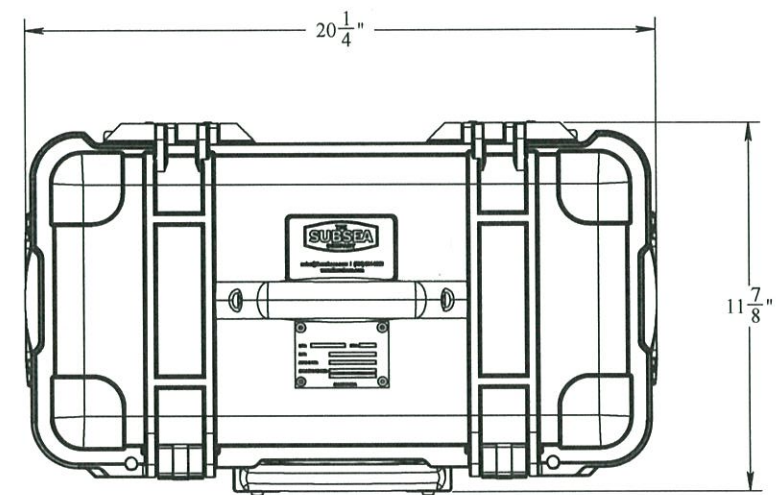

FIVE 20' HOSES WITH INLINE VALVES AND 1/4" SAE HOSE CONNECTIONS (SE-0968)

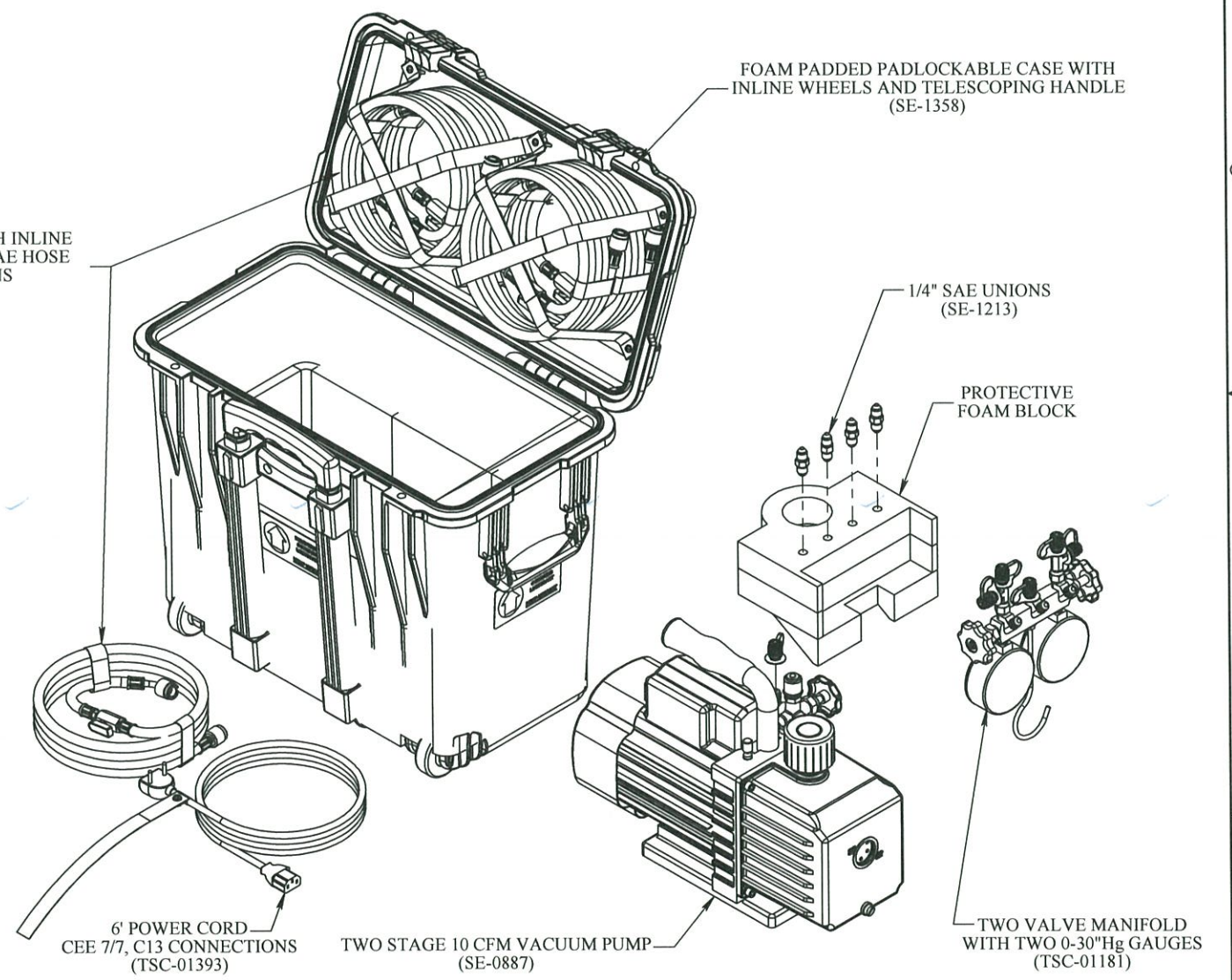

**SPECIFICATIONS:**

- 10 CFM TWO STAGE VACUUM PUMP, 220VAC, 50/60Hz, 1/2 HP, 3440 RPM.
- 6' POWER CORD WITH CEE 7/7 AND C13 CONNECTIONS.
- TWO VALVE VACUUM MANIFOLD WITH TWO 3-1/8" 0-30"Hg GAUGES.
- 1/4" SAE CONNECTIONS WITH DUST CAPS.
- FIVE 20' 1/4" SAE HOSE SETS WITH INLINE ISOLATION VALVES AND KNURLED KNOBS REQUIRING ONLY FINGER TIGHT CONNECTIONS.
- FOUR 1/4" SAE STAINLESS STEEL UNIONS TO INTERCONNECT HOSES IF NEEDED.
- FOAM PADDED RUGGED PADLOCKABLE CASE WITH INLINE WHEELS AND TELESCOPING HANDLE.
- DESIGNED TO WORK WITH VACUUM CHART RECORDER SYSTEM TSC-01180.
- WEIGHT 59 LBS.

<b>PROPRIETARY AND CONFIDENTIAL:</b> THE INFORMATION CONTAINED IN THIS DRAWING IS THE SOLE PROPERTY OF THE SUBSEA COMPANY INC. ANY REPRODUCTION IN PART OR AS A WHOLE WITHOUT THE WRITTEN PERMISSION OF THE SUBSEA COMPANY INC IS PROHIBITED.		<b>WORKMANSHIP STANDARD</b> PER WI 751-001		<table border="1"> <tr> <td>NAME</td> <td>DATE</td> </tr> <tr> <td><i>CMB</i></td> <td>11-19-14</td> </tr> <tr> <td>CHECKED</td> <td><i>RJ</i> 11-20-14</td> </tr> <tr> <td>Q.A.</td> <td><i>RJ</i> 11-19-14</td> </tr> <tr> <td>MFG APPR.</td> <td><i>RJ</i> 11-21-14</td> </tr> </table>		NAME	DATE	<i>CMB</i>	11-19-14	CHECKED	<i>RJ</i> 11-20-14	Q.A.	<i>RJ</i> 11-19-14	MFG APPR.	<i>RJ</i> 11-21-14			<b>THE SUBSEA COMPANY INC</b>	
NAME	DATE																		
<i>CMB</i>	11-19-14																		
CHECKED	<i>RJ</i> 11-20-14																		
Q.A.	<i>RJ</i> 11-19-14																		
MFG APPR.	<i>RJ</i> 11-21-14																		
3RD ANGLE PROJECTION:		INTERPRET GEOMETRIC TOLERANCING PER: ASME Y14.5		UNLESS OTHERWISE SPECIFIED: ALL DIMENSIONS ARE IN INCHES		SCALE: 1:10		SIZE <b>B</b> TITLE: VACUUM PUMP ASSEMBLY WITH CASE, 10 CFM REV <b>C1</b>											
WEIGHT: 59.0 lbs.		DO NOT SCALE DRAWING		DWG. NO. TSC-01179-GA		SHEET 1 OF 1													