

8 7 6 5 4 3 2 1

REVISIONS				
REV.	DESCRIPTION	ECO #	DATE	APPROVED
A1	RELEASE	2014-178	5/29/2014	CWB

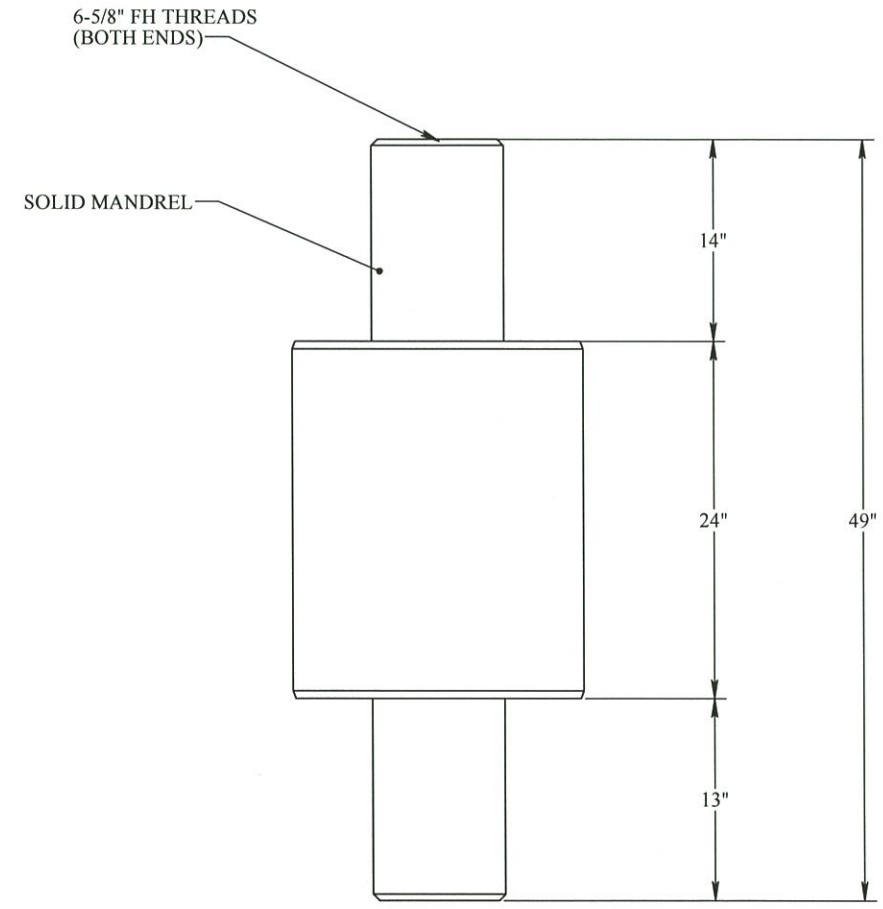
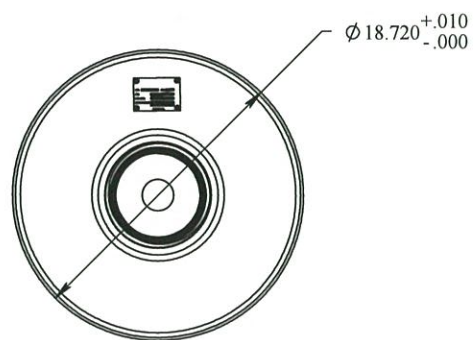

DRIFT FEATURES

1. OUTSIDE DIAMETER 18.720 +.010-.000
2. 6-5/8" FH BOX x BOX
3. DESIGNED IAW WITH API SPECIFICATION 7, MEETS OR EXCEEDS REQUIREMENTS OF TABLE 7
4. MAKE-UP WITH CHAIN TONGS
5. WORKING LOAD 10,000 LBS
6. PULL TESTED TO 15,000 LBS
7. APPROXIMATE WEIGHT: 1162 LBS
8. MILD STEEL CONSTRUCTION (36 KSI)
9. DRIFT IS DESIGNED FOR SURFACE TESTING ONLY

PROPRIETARY AND CONFIDENTIAL:
 THE INFORMATION CONTAINED IN THIS DRAWING IS THE SOLE PROPERTY OF THE SUBSEA COMPANY INC. ANY REPRODUCTION IN PART OR AS A WHOLE WITHOUT THE WRITTEN PERMISSION OF THE SUBSEA COMPANY INC IS PROHIBITED.

3RD ANGLE PROJECTION:

INTERPRET GEOMETRIC TOLERANCING PER: ASME Y14.5

WORKMANSHIP STANDARD PER WI 751-001

UNLESS OTHERWISE SPECIFIED: ALL DIMENSIONS ARE IN INCHES

	NAME	DATE
DRAWN	TLC	5/29/14
CHECKED	GREG	6/10/14
Q.A.	RUD	6/11/14
MFG APPR.	TIM	6/24/14

		THE SUBSEA COMPANY INC	
SIZE B	TITLE: DRIFT, 18-3/4" API, 23" BODY, 6-5/8" FH BOX x BOX	REV A1	DWG. NO. TSC-02128-GA
DO NOT SCALE DRAWING		SHEET 1 OF 1	

8 7 6 5 4 3 2 1