

REVISIONS				
REV.	DESCRIPTION	ECO #	DATE	APPROVED
A1	RELEASE	2019-069	6/21/2019	
A3	CHANGED DESCRIPTION & NOTES	2023-070	10/11/2023	

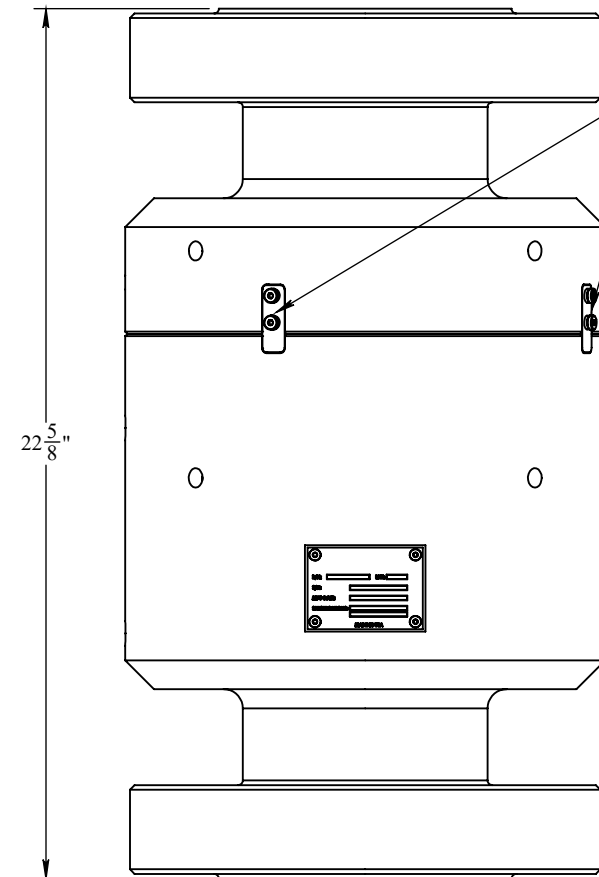
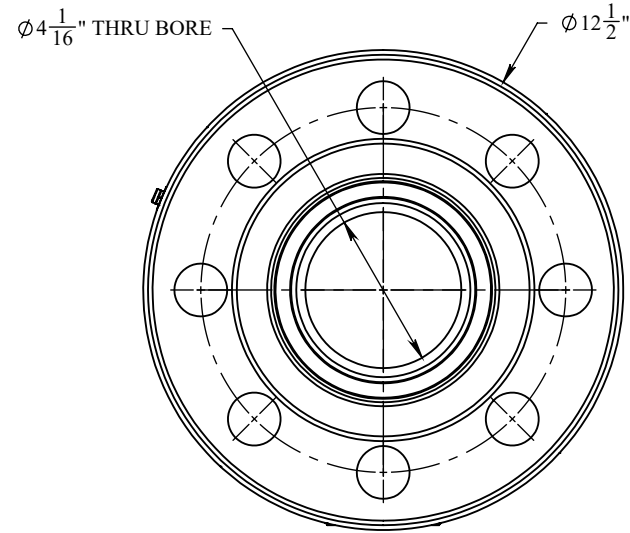

ANTI-ROTATION TABS
(2 ON BACKSIDE)

LEAKAGE INDICATING PORT
(1 ON BACKSIDE)

GREASE PORTS
(2 ON BACKSIDE)

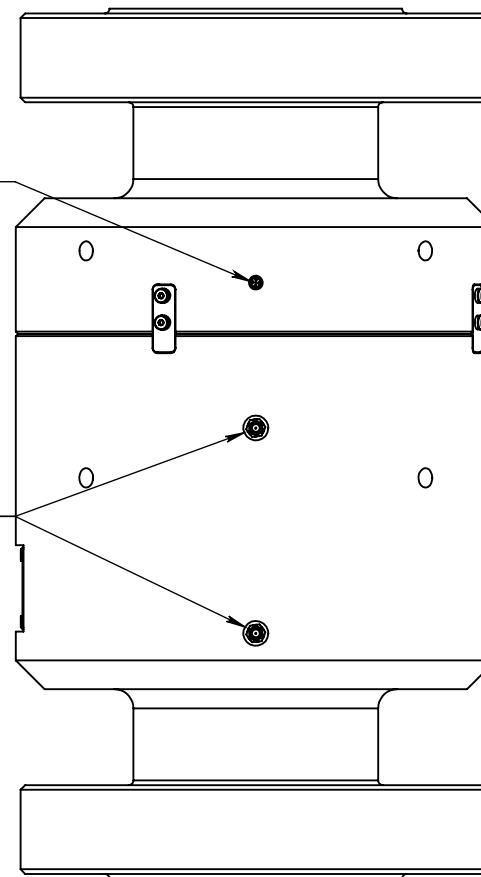

ACCESSORIES

PART NO.	DESCRIPTION	QTY.
SE-1112	GREASE, SYNTHETIC, INDUSTRIAL, LC 2, NLGI GRADE 1.5	42 oz.
SE-2150	GASKET, BX-155, 316SS	2

SPARE PARTS

PART NO.	DESCRIPTION	QTY.
TSC-02456-SK	KIT, SEAL	1
TSC-02456-BK	KIT, BALL BEARING	1

NOTES:

- DESIGNED FOR MUD BOOST LINES
- MEET NACE MR0175 FOR H2S SERVICE
- PRESSURE CONTAINING PARTS ARE BUILT FROM STAINLESS STEEL
- WORKING PRESSURE - 5K PSI MAX
- TESTED AT 1.5 TIMES WORKING PRESSURE
- 4-1/16" API 17D SS FLANGE
- ONE PRIMARY SEAL AND TWO BACK UP SEALS
- FOUR GREASE PORTS
- TWO LEAKAGE INDICATING PORTS
- DESIGNED WITH HEAVY DUTY BEARINGS FOR HIGH LOAD SERVICE

STANDARDS AND REGULATIONS

- API 6A-SPECIFICATIONS FOR VALVES AND WELL-HEAD EQUIPMENT
- API 16A-SPECIFICATIONS FOR DRILL-THROUGH EQUIPMENT.
- API 17D-DESIGN AND OPERATION OF SUBSEA PRODUCTION SYSTEM
- ABS CLASSIFICATION OF DRILLING SYSTEM-AVAILABLE

PROPRIETARY AND CONFIDENTIAL:
THE INFORMATION CONTAINED IN THIS DRAWING IS THE SOLE PROPERTY OF THE SUBSEA COMPANY INC. ANY REPRODUCTION IN PART OR AS A WHOLE WITHOUT THE WRITTEN PERMISSION OF THE SUBSEA COMPANY INC IS PROHIBITED.

3RD ANGLE PROJECTION:

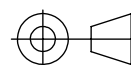

INTERPRET GEOMETRIC TOLERANCING PER: ASME Y14.5

WORKMANSHIP STANDARD PER WI 751-001

UNLESS OTHERWISE SPECIFIED: ALL DIMENSIONS ARE IN INCHES

WEIGHT: 355.19 LBS.

	NAME	DATE
DRAWN	TLC	10/11/2023
CHECKED	AC	10/11/2023
APPROVED	TAC	10/11/2023

		THE SUBSEA COMPANY INC	
		SIZE B	TITLE: SWIVEL, MUD BOOST, 5K WP, API 17D 4-1/16" BX-155 5K FLANGE X FLANGE
DWG. NO. TSC-02456-GA			REV A3
SHEET 1 OF 1			