

REVISIONS				
REV.	DESCRIPTION	ECO #	DATE	APPROVED
A1	INITIAL RELEASE	2012-259	7/10/2012	SKY

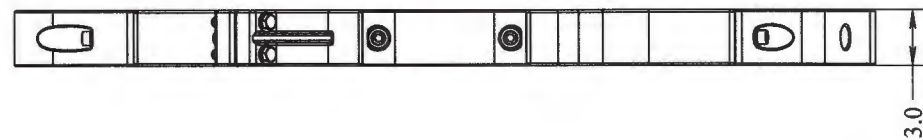

**NOT APPROVED FOR MANUFACTURING  
FOR CUSTOMER APPROVAL ONLY**

**PROPRIETARY AND CONFIDENTIAL:**  
THE INFORMATION CONTAINED IN THIS DRAWING IS THE SOLE PROPERTY OF THE SUBSEA COMPANY INC. ANY REPRODUCTION IN PART OR AS A WHOLE WITHOUT THE WRITTEN PERMISSION OF THE SUBSEA COMPANY INC IS PROHIBITED.

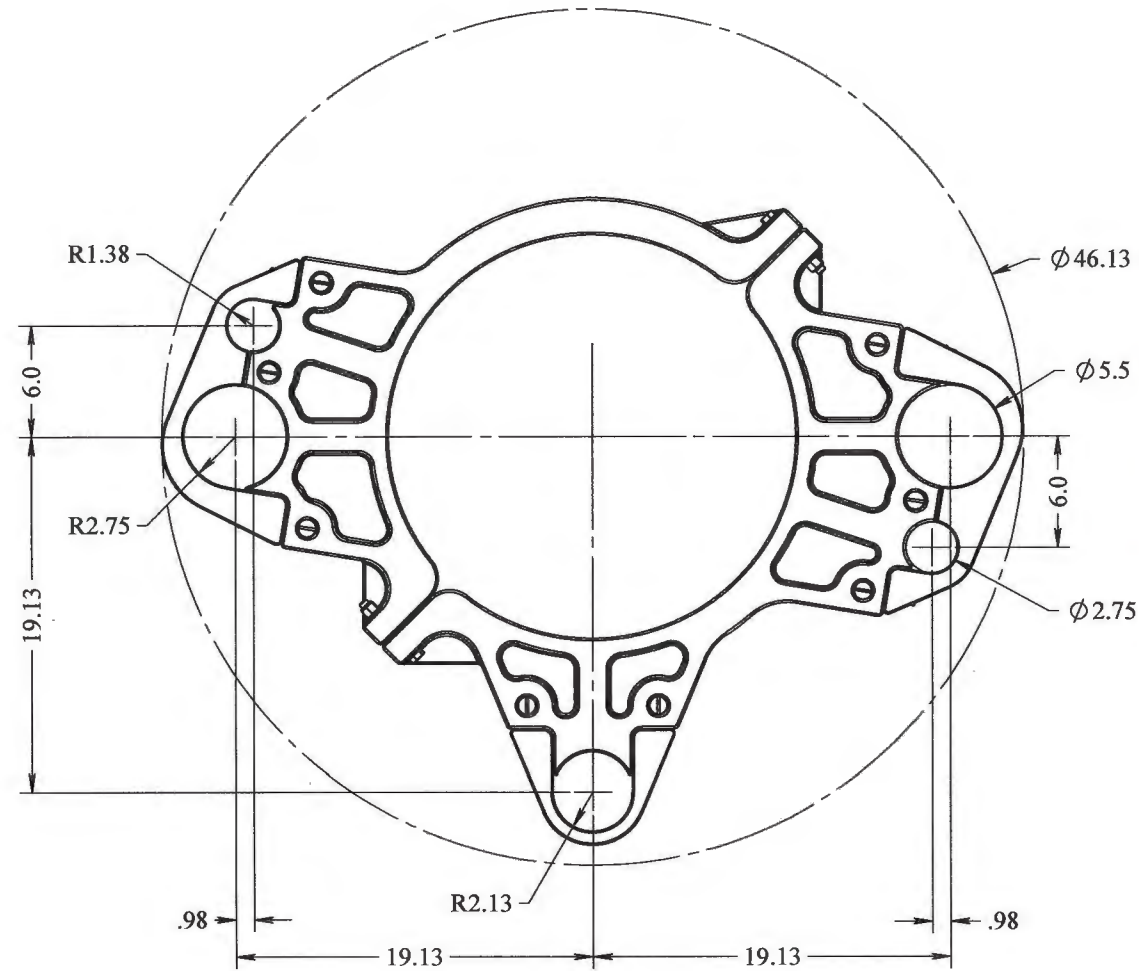
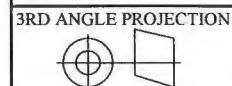

INTERPRET GEOMETRIC TOLERANCING PER: ASME Y14.5

UNLESS OTHERWISE SPECIFIED  
ALL DIMENSIONS ARE IN INCHES  
STANDARD TOLERANCES:  
ANGULAR: MACH ± 1.0°  
ZERO PLACE DECIMAL ± 0.060  
ONE PLACE DECIMAL ± 0.030  
TWO PLACE DECIMAL ± 0.010  
THREE PLACE DECIMAL ± 0.005  
FRACTION ± 1/16  
SURFACE FINISH 125 RA  
BREAK ALL EDGES MIN .01"

WORKMANSHIP STANDARD  
PER WI 751-001

VOLUME:  
MATERIAL:  
FINISH:  
WEIGHT: 46.50 lbs.

	NAME	DATE
DRAWN	GMB	7/10/2012
CHECKED	SKY	7/10/12
Q.A.		
MFG APPR	Ru	7/10/12
DO NOT SCALE DRAWING		



**THE SUBSEA COMPANY INC**

SIZE  
**B**

TITLE:  
RISER CLAMP ASSEMBLY, TYPE VII

REV  
**A1**

DWG. NO. TSC-00723-GA

SHEET 1 OF 1