

ITEM NO.	PART NUMBER	DESCRIPTION	QTY.
10	TSC-01133	BUMPER, SLIC JOINT, RETRACTABLE MUX CLAMP	1
20	TSC-00323-6	U-BOLT, 1/2"-13 x 2" THREAD, 6 3/4" ID, 7 3/8" LENGTH	2
30	TSC-01135	TUBE, RUBBER, NEOPRENE, 1/2" ID X 5/8" OD, 11 3/8" LG.	2
40	FN-00116	WASHER, FLAT, 1/2", 1-1/2" OD, 316 SS	4
50	FN-NE12S	NUT, NYLON LOCK, 1/2" - 13UNC, SS	4

REVISIONS				
REV.	DESCRIPTION	ECO #	DATE	APPROVED
A1	RELEASE	2013-308	7/22/13	GNB
A2	CHANGED FN-00117 TO FN-NE12S	2013-343	8/22/2013	GNB
A3	ADDED U-BOLTS FOR CLAMP	2013-515	12/23/2013	GNB
B1	REMOVED EXTRA U-BOLTS	2014-312	8/4/2014	<i>GNB</i>

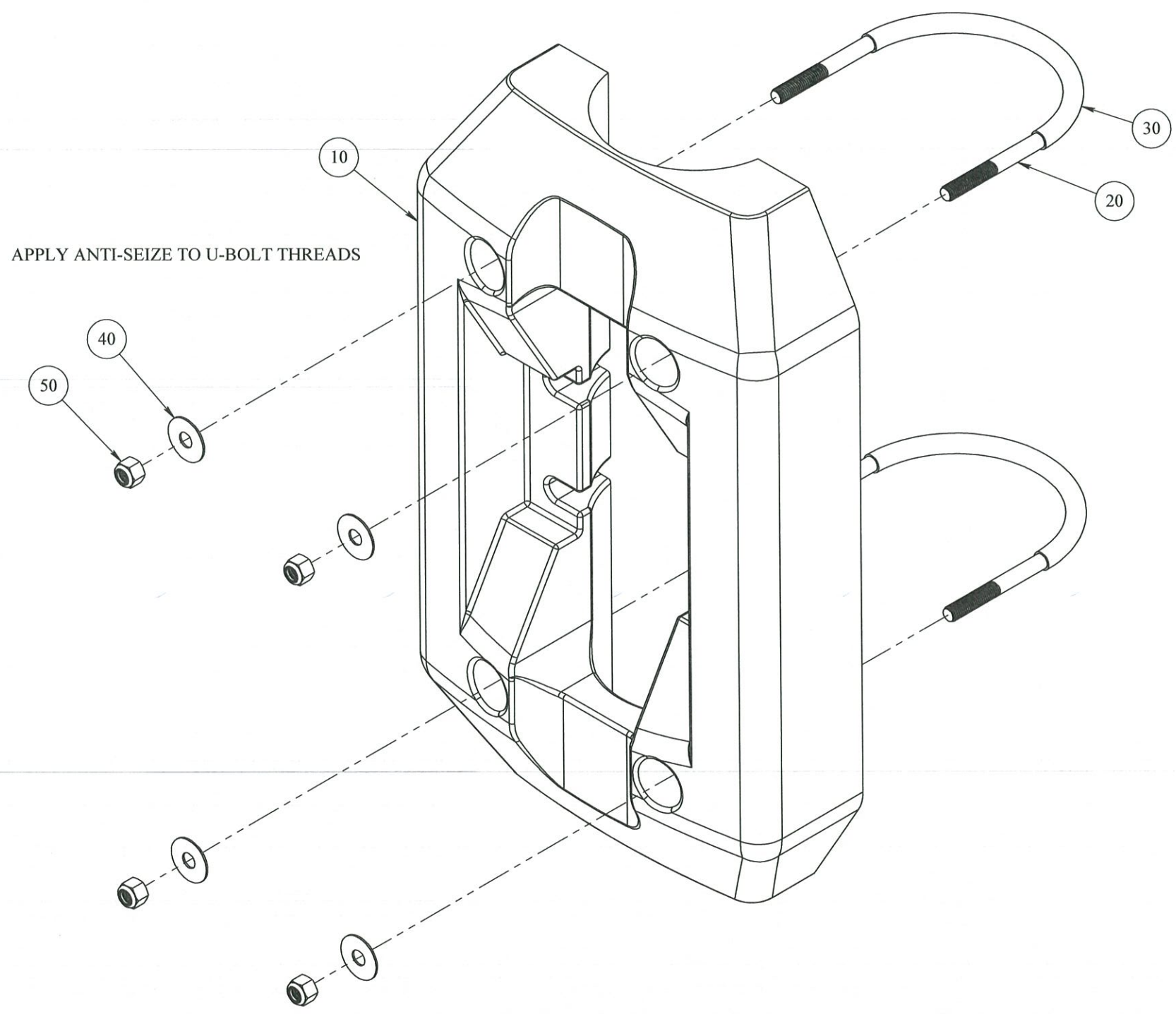

<b>PROPRIETARY AND CONFIDENTIAL:</b> THE INFORMATION CONTAINED IN THIS DRAWING IS THE SOLE PROPERTY OF THE SUBSEA COMPANY INC. ANY REPRODUCTION IN PART OR AS A WHOLE WITHOUT THE WRITTEN PERMISSION OF THE SUBSEA COMPANY INC IS PROHIBITED.	WORKMANSHIP STANDARD PER WI 751-001	NAME: <i>CRS</i> DATE: <i>8-5-14</i> CHECKED: <i>RLO</i> <i>8-5-14</i> Q.A.: <i>RLO</i> <i>8-5-14</i> MFG APPR.: <i>RLO</i> <i>8-5-14</i>		<b>THE SUBSEA COMPANY INC</b>	
	3RD ANGLE PROJECTION:	UNLESS OTHERWISE SPECIFIED: ALL DIMENSIONS ARE IN INCHES		SCALE: 1:12	SIZE: <b>B</b>
INTERPRET GEOMETRIC TOLERANCING PER: ASME Y14.5	WEIGHT: 46.61 lbs.	DO NOT SCALE DRAWING	DWG. NO. TSC-01134	SHEET 1 OF 1	