

REVISIONS				
REV.	DESCRIPTION	ECO #	DATE	APPROVED
A1	RELEASE	2016-069	8/16/2016	GNB

ACCESSORIES		
PART NO.	DESCRIPTION	QUANTITY
SE-1112	GREASE, SYNTHETIC, INDUSTRIAL, LC 1.5	14 oz
SE-0019	RING GASKET, 3 1/16", BX154	2

TSC-01931-SK SEAL KIT		
PART NO.	DESCRIPTION	QUANTITY
SE-1241	SEAL, POLYPAK TYPE-B, 3" ID X 3.5" OD X 0.413" TALL	3
SE-1016	O-RING, 2-450	1
SE-1005	RADIAL SHAFT SEAL, 5.5" ID X 6.625" OD X .562 WIDTH	1

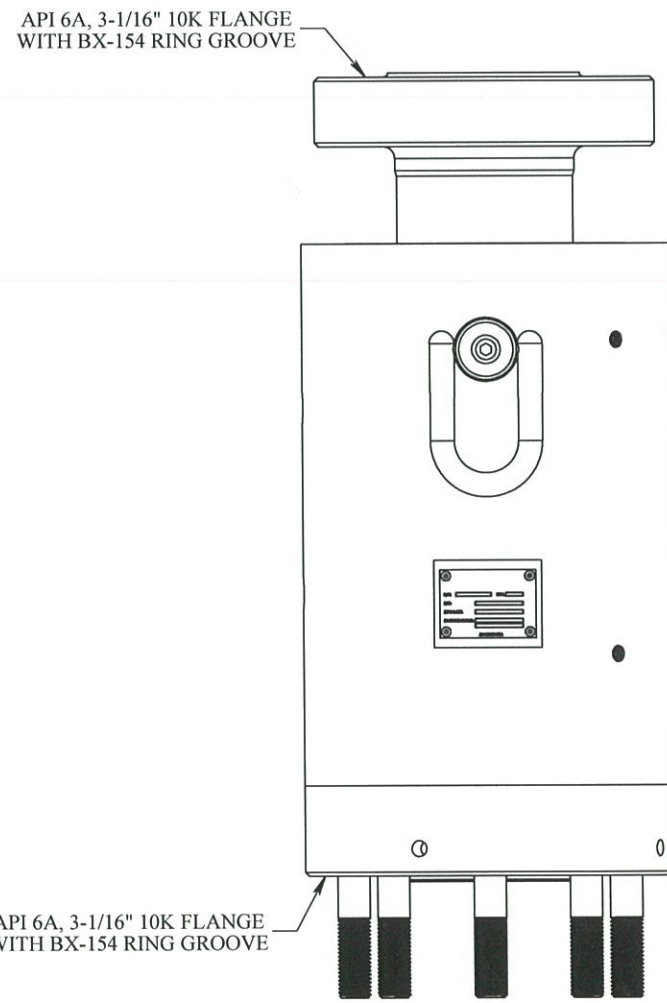
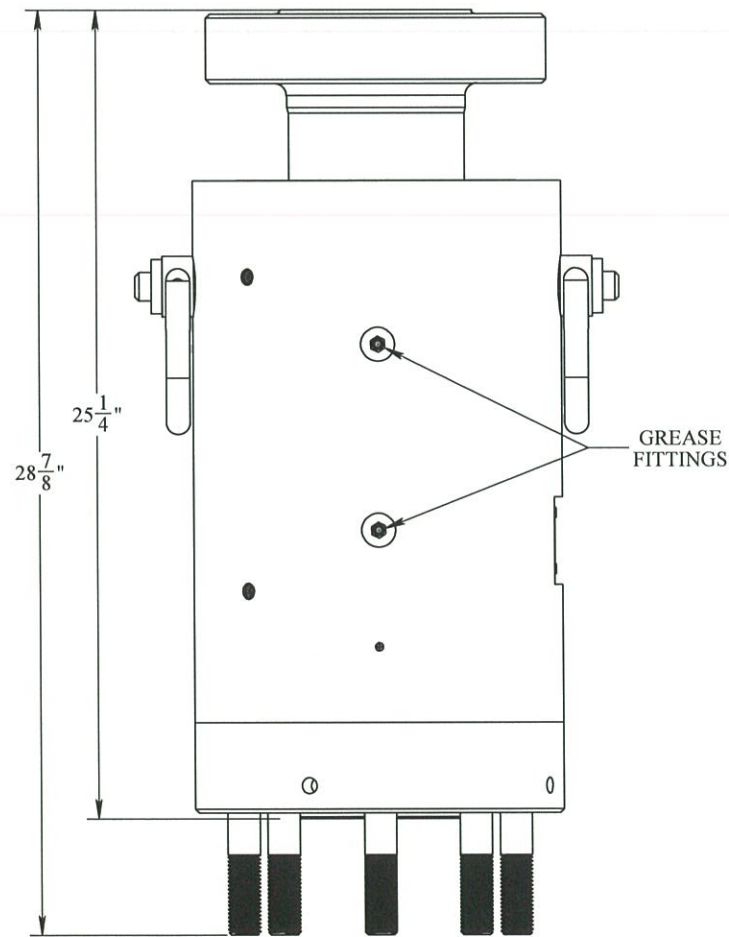
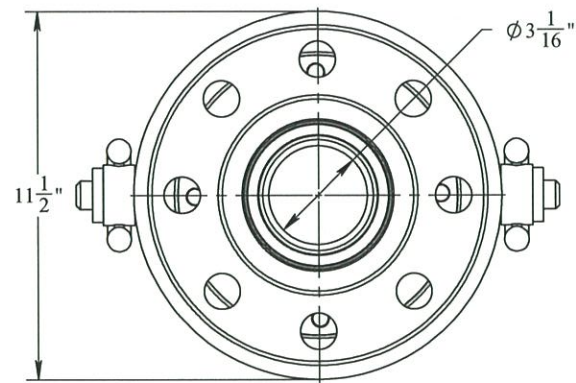

- NOTES:**
1. WETTED SURFACES ARE CORROSION RESISTANT MATERIAL INCLUDING RING GROOVES.
 2. RATED AT 5,000 PSI WORKING PRESSURE.
 3. TESTED AT 1.5 TIMES WORKING PRESSURE.
 4. BOLTED CONNECTION ON ONE END AND STUD CONNECTION ON THE OTHER.
 5. TWO (2) REMOVABLE LIFTING RINGS FOR RIGGING THE SWIVEL RATED FOR A COMBINED 2,000 LBS LIFTING CAPACITY AT 90 DEGREES.
 6. TWO (2) ZERK FITTINGS TO FEED GREASE TO THE BEARINGS.

- STANDARDS & REGULATIONS**
7. API 6A - SPECIFICATIONS FOR VALVES AND WELL-HEAD EQUIPMENT.
 8. API 16D - SPECIFICATIONS FOR CONTROL SYSTEMS FOR DRILLING WELL CONTROL EQUIPMENT.
 9. API 17D - SPECIFICATIONS FOR SUBSEA WELL-HEAD AND CHRISTMAS TREE EQUIPMENT.

PROPRIETARY
THE INFORMATION CONTAINED IN THIS DRAWING IS THE SOLE PROPERTY OF THE SUBSEA COMPANY INC.

3RD ANGLE PROJECTION:

INTERPRET GEOMETRIC TOLERANCING PER: ASME Y14.5

WORKMANSHIP STANDARD PER WI 751-001

UNLESS OTHERWISE SPECIFIED:
ALL DIMENSIONS ARE IN INCHES

WEIGHT: 573.25 lbs.

	NAME	DATE
DRAWN	GIREL	8/30/16
CHECKED	DC	8/30/16
Q.A.	AMES	8/30/16
MFG APPR.	RAF	8/30/16

THE SUBSEA COMPANY THE SUBSEA COMPANY INC

SIZE: **B** TITLE: SWIVEL, 5K, API 6A, 3-1/16" 10K FLANGE WITH BX-154 RING GROOVE

DWG. NO. TSC-01931-GA-SALES SHEET 1 OF 1

REV **A1**