

ITEM NO.	PART NUMBER	DESCRIPTION	QTY.
10	TSC-01098	GE VETCO, P/N 195394-18, 5" LONG x 3" WIDE x 3/8" THICK, NEOPRENE STRIP, 70 DUROMETER	1
20	TSC-01097	GE VETCO, P/N H12604-1 RISER JT-DRLG PART, HMF, 21.000, RETAINING SEGMENT, DETAIL	1
30	TSC-01101	GE VETCO, P/N 195017-378 (REV G); CAP SCREW, HEX HEAD, 1.000-8UNRC-2A x 2.250" LG, MATL PER=SAE GR 5, COAT PER=ZINC	1
40	TSC-01144	GE VETCO, P/N H12447-4, RISER JT-DRLG PART, HMF-H, 21.250 OD, DEFLECTOR SEGMENT, BOX END	1

REVISIONS				
REV.	DESCRIPTION	ECO #	DATE	APPROVED
A1	RELEASE	2013-275	6/13/2013	CMB

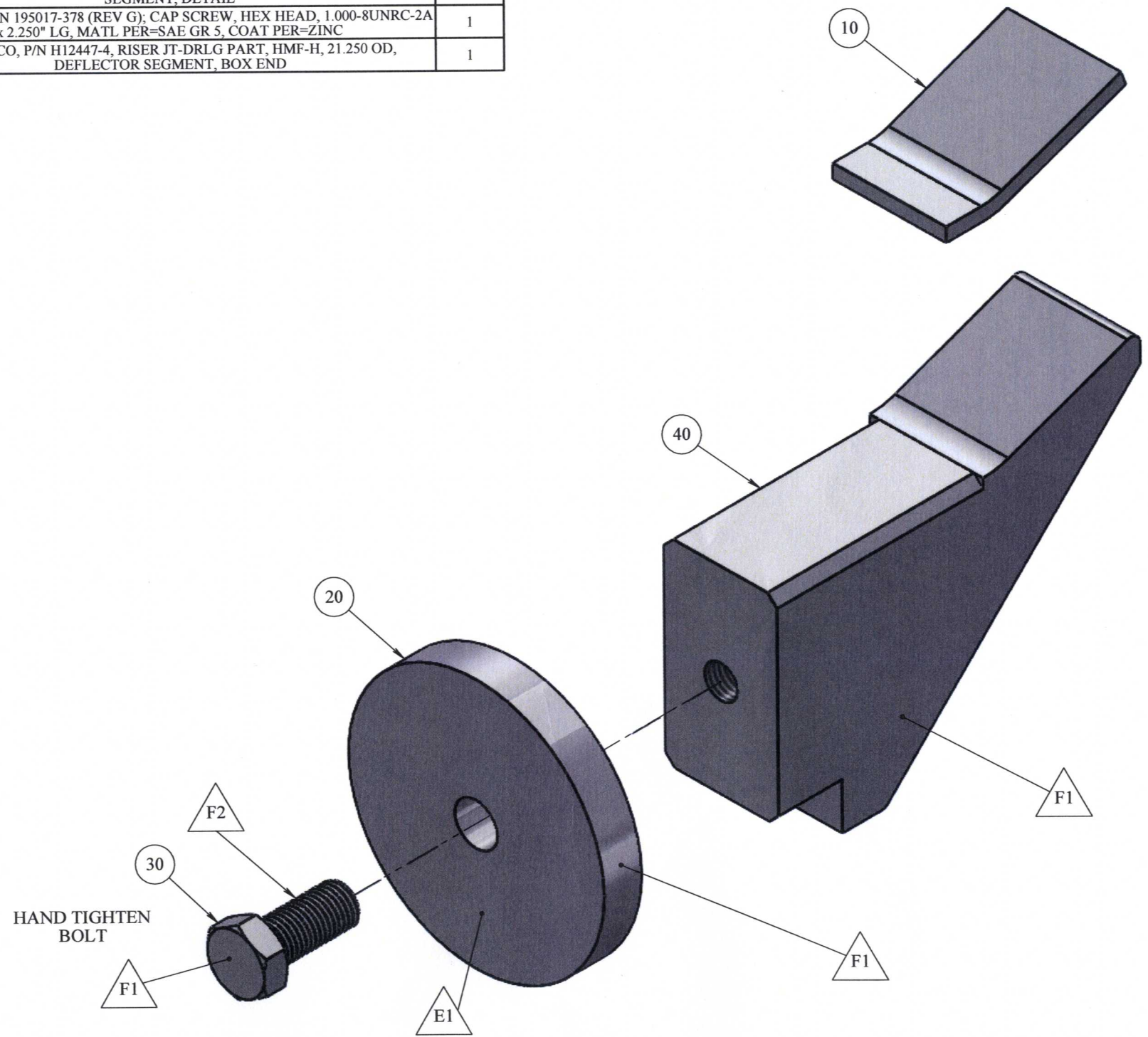

NOTES:

1. \triangle_{E1} LOW STRESS STAMP "P/N H12446-6 NC"
2. \triangle_{F1} APPLY CORROSION INHIBITOR (SUBSEA P/N MS-0150) AS PER GE SPEC. VGS 6.4.1, COAT ALL EXPOSED UNPROTECTED AREAS
3. \triangle_{F2} APPLY NEVER-SEEZ (SUBSEA P/N MS-0062-05) TO MALE THREADS OF 1"-8 HEX HEAD CAP SCREW AS PER LABEL INSTRUCTIONS.
4. CUSTOMER APPLIES FINAL COATING AND GLUES ON NEOPRENE STRIP.

PROPRIETARY AND CONFIDENTIAL:
 THE INFORMATION CONTAINED IN THIS DRAWING IS THE SOLE PROPERTY OF THE SUBSEA COMPANY INC. ANY REPRODUCTION IN PART OR AS A WHOLE WITHOUT THE WRITTEN PERMISSION OF THE SUBSEA COMPANY INC IS PROHIBITED.

3RD ANGLE PROJECTION:

INTERPRET GEOMETRIC TOLERANCING PER: ASME Y14.5

WORKMANSHIP STANDARD PER WI 751-001

UNLESS OTHERWISE SPECIFIED: ALL DIMENSIONS ARE IN INCHES

WEIGHT: 14.23 lbs.

	NAME	DATE
DRAWN	GREG	6-14-13
CHECKED	CATR	6-14-13
Q.A.	CATR	6-14-13
MFG APPR.	TPSMT	6-14-13

SCALE: 1:8

DO NOT SCALE DRAWING

THE SUBSEA COMPANY INC

SIZE: **B**

TITLE: RISER JT-DRLG PART, HMF, 21.25 OD, DEFLECTOR ASSEMBLY, WITH GUSSETS, BOX END

REV: **A1**

DWG. NO. TSC-01137

SHEET 1 OF 1