

REVISIONS				
REV.	DESCRIPTION	ECO #	DATE	APPROVED
A2	CORRECTED RING GASKET PART NUMBER	2016-085	10/28/2016	GMB

ACCESSORIES		
PART NUMBER	DESCRIPTION	QTY.
SE-1112	GREASE, SYNTHETIC, INDUSTRIAL, LC 1.5	14 OUNCES
SE-0020	RING GASKET, 4-1/16", BX-155	2

TSC-01685-SK SEAL KIT, SWIVEL, 7.5K		
PART NUMBER	DESCRIPTION	QTY.
SE-1486	POLYPAK, TYPE B, 5" ID x 6" OD x .825" TALL, POLYMITE, BLACK	2
SE-1485	POLYPAK, STANDARD, 5.5" ID x 6.5" OD x .550" TALL	1
SE-0545-1	O-RING, 2-449	1
SE-0846	SEAL, RADIAL, 6-1/2" SHAFT	1
SE-0757	SEAL, RADIAL, 8-1/2" SHAFT	1

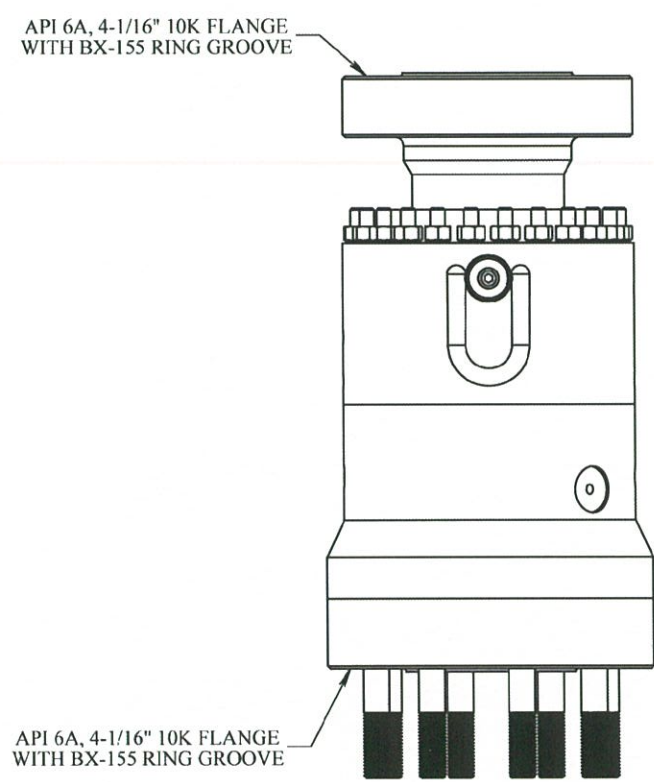
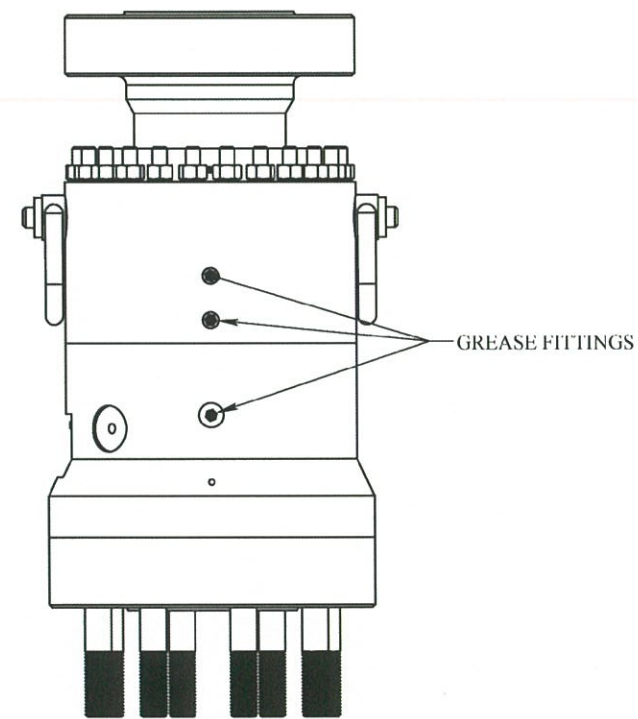
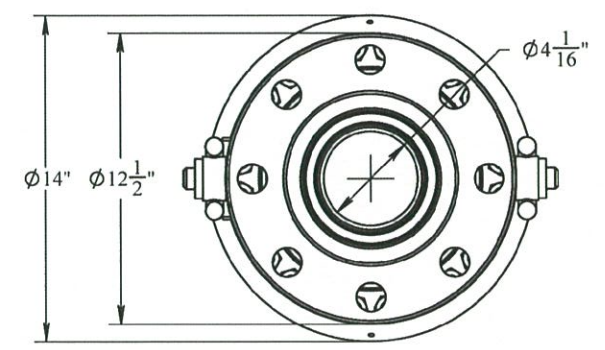

- NOTES:**
1. WETTED SURFACES ARE CORROSION RESISTANT MATERIAL INCLUDING RING GROOVES.
  2. RATED AT 7,500 PSI WORKING PRESSURE.
  3. TESTED AT 1.5 TIMES WORKING PRESSURE.
  4. BOLTED CONNECTION ON ONE END AND STUD CONNECTION ON THE OTHER.
  5. TWO (2) REMOVABLE LIFTING RINGS FOR RIGGING THE SWIVEL RATED FOR A COMBINED 5,000 LBS VERTICAL LIFTING CAPACITY.
  6. THREE (3) ZERK FITTINGS TO FEED GREASE TO THE BEARINGS.
- STANDARDS & REGULATIONS:**
7. API 6A - SPECIFICATIONS FOR VALVES AND WELL-HEAD EQUIPMENT.
  8. API 16C - SPECIFICATIONS FOR CHOKE AND KILL SYSTEMS
  9. API 17D - SPECIFICATIONS FOR SUBSEA WELL-HEAD AND CHRISTMAS TREE EQUIPMENT.
  10. MEETS NACE MR0175

**PROPRIETARY AND CONFIDENTIAL:**  
 THE INFORMATION CONTAINED IN THIS DRAWING IS THE SOLE PROPERTY OF THE SUBSEA COMPANY INC. ANY REPRODUCTION IN PART OR AS A WHOLE WITHOUT THE WRITTEN PERMISSION OF THE SUBSEA COMPANY INC IS PROHIBITED.

3RD ANGLE PROJECTION:

INTERPRET GEOMETRIC TOLERANCING PER: ASME Y14.5

WORKMANSHIP STANDARD PER W1 751-001

UNLESS OTHERWISE SPECIFIED:  
 ALL DIMENSIONS ARE IN INCHES

WEIGHT: 702 LBS.

	NAME	DATE
DRAWN	GREG	10-28-16
CHECKED	DC	10-29-16
MFG./SALES	Ron	10-28-16

<b>THE SUBSEA COMPANY INC</b>		REV
SIZE	TITLE:	A2
<b>B</b>	SWIVEL, 7.5K, API 6A, 4-1/16" 10K FLANGE WITH BX-155 RING GROOVE	
DWG. NO.	TSC-01936-GA-SALES	SHEET 1 OF 1