

8 7 6 5 4 3 2 1

| REVISIONS | | | | |
|-----------|-------------|----------|-----------|----------|
| REV. | DESCRIPTION | ECO.# | DATE | APPROVED |
| A1 | RELEASE | 2013-352 | 8/28/2013 | GNB |

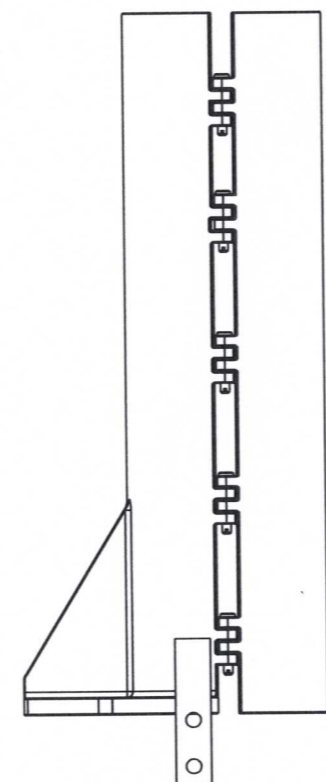
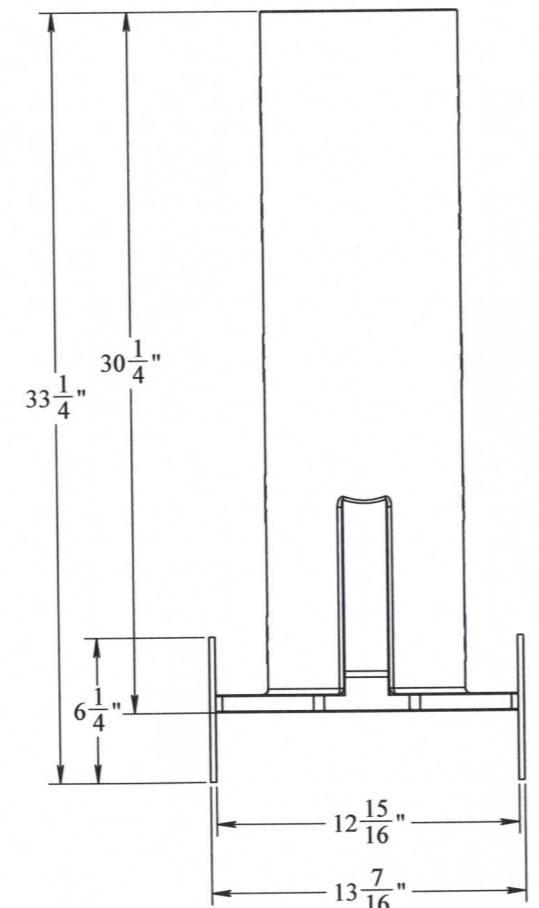
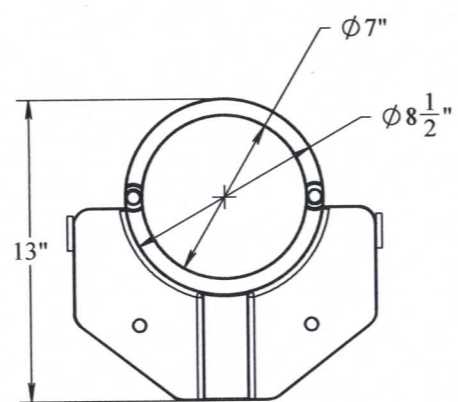

**NOT APPROVED FOR MANUFACTURING
FOR CUSTOMER APPROVAL ONLY**

| | | | |
|--|---|--|--|
| PROPRIETARY AND CONFIDENTIAL: THE INFORMATION CONTAINED IN THIS DRAWING IS THE SOLE PROPERTY OF THE SUBSEA COMPANY INC. ANY REPRODUCTION IN PART OR AS A WHOLE WITHOUT THE WRITTEN PERMISSION OF THE SUBSEA COMPANY INC IS PROHIBITED. | WORKMANSHIP STANDARD PER WI 751-001 | DRAWN: GREG 8-28-13 CHECKED: J.C. 8-28-13 Q.A. CAES 8-28-13 MFG APPR. TPAAT 8-28-13 | THE SUBSEA COMPANY INC |
| | UNLESS OTHERWISE SPECIFIED: ALL DIMENSIONS ARE IN INCHES | SCALE: 1:8 | |
| 3RD ANGLE PROJECTION: | INTERPRET GEOMETRIC TOLERANCING PER: ASME Y14.5 | WEIGHT: 76.980 lbs. | DWG. NO. TSC-TC-01-BOM-03-GA SHEET 1 OF 1 |

8 7 6 5 4 3 2 1