

REVISIONS				
REV.	DESCRIPTION	ECO #	DATE	APPROVED
C1	ADDED TABLES FOR SPARE AND REPAIR PARTS KITS	2014-488	11/19/14	CNB

TSC-01179-SK SPARES, KIT, VACUUM PUMP ASSEMBLY WITH CASE, 10 CFM		
PART NUMBER	DESCRIPTION	QTY.
SE-01235	OIL, VACUUM PUMP, QUART BOTTLE	1
TSC-01393	POWER CORD, WITH VELCRO STRAP, VACUUM SYSTEM	1
SE-0968	HOSE, 20' RED STANDARD IN-LINE BALL VALVE HOSE, CPS	2
SE-1010	CAP, 1/4" SAE, PLASTIC, W/STRAP	6
SE-1213	UNION, 1/4" JIC MALE X 1/4" JIC MALE, 316SS	2

TSC-01179-RK REPAIR, KIT, VACUUM PUMP ASSEMBLY WITH CASE, 10 CFM		
PART NUMBER	DESCRIPTION	QTY.
TSC-01179-SK	SPARES, KIT, VACUUM PUMP ASSEMBLY WITH CASE, 10 CFM	1
TSC-01181	VACUUM GAUGE MANIFOLD ASSEMBLY, 0-30"Hg.	1
SE-0887	PUMP, VACUUM, 10 CFM, 110/220 VAC	1

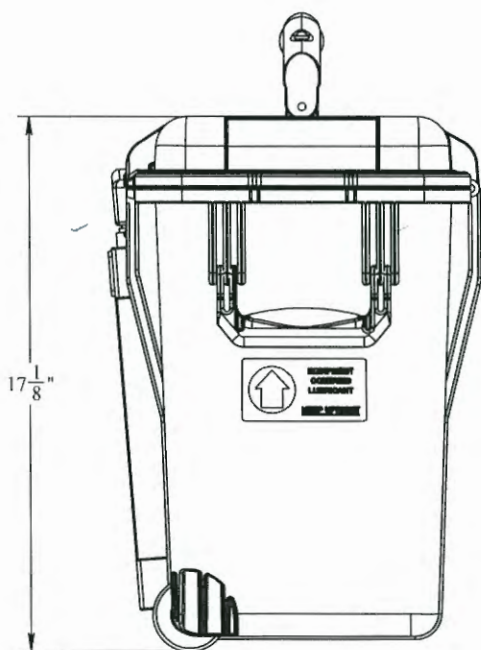
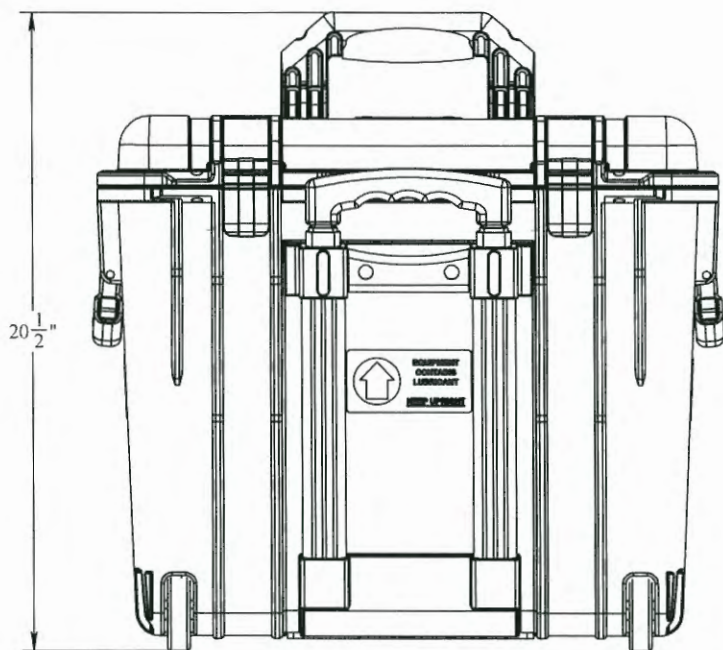
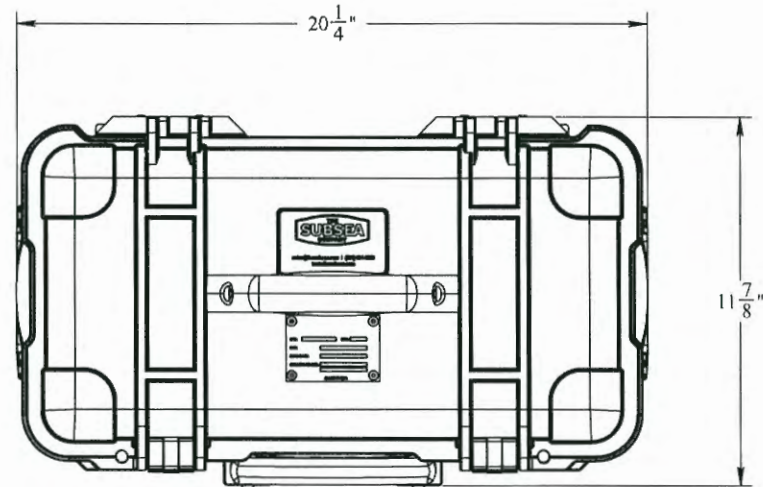

FIVE 20' HOSES WITH INLINE VALVES AND 1/4" SAE HOSE CONNECTIONS (SE-0968)

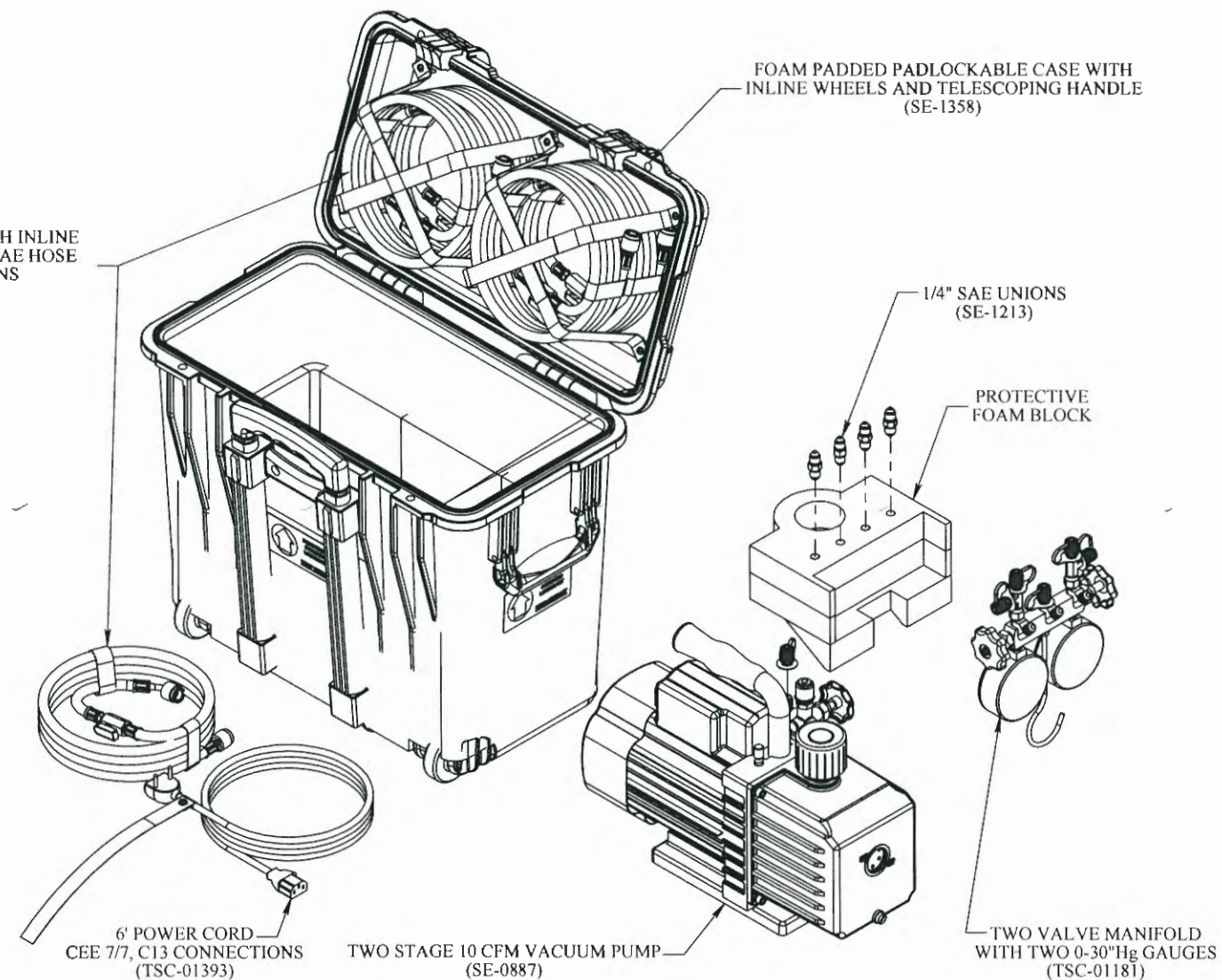

**SPECIFICATIONS:**

- 10 CFM TWO STAGE VACUUM PUMP, 220VAC, 50/60Hz, 1/2 HP, 3440 RPM.
- 6' POWER CORD WITH CEE 7/7 AND C13 CONNECTIONS.
- TWO VALVE VACUUM MANIFOLD WITH TWO 3-1/8" 0-30"Hg GAUGES.
- 1/4" SAE CONNECTIONS WITH DUST CAPS.
- FIVE 20' 1/4" SAE HOSE SETS WITH INLINE ISOLATION VALVES AND KNURLED KNOBS REQUIRING ONLY FINGER TIGHT CONNECTIONS.
- FOUR 1/4" SAE STAINLESS STEEL UNIONS TO INTERCONNECT HOSES IF NEEDED.
- FOAM PADDED RUGGED PADLOCKABLE CASE WITH INLINE WHEELS AND TELESCOPING HANDLE. DESIGNED TO WORK WITH VACUUM CHART RECORDER SYSTEM TSC-01180.
- WEIGHT 59 LBS.

**PROPRIETARY AND CONFIDENTIAL:**  
 THE INFORMATION CONTAINED IN THIS DRAWING IS THE SOLE PROPERTY OF THE SUBSEA COMPANY INC. ANY REPRODUCTION IN PART OR AS A WHOLE WITHOUT THE WRITTEN PERMISSION OF THE SUBSEA COMPANY INC IS PROHIBITED.

3RD ANGLE PROJECTION:

INTERPRET GEOMETRIC TOLERANCING PER: ASME Y14.5

WORKMANSHIP STANDARD PER WI 751-001

UNLESS OTHERWISE SPECIFIED: ALL DIMENSIONS ARE IN INCHES

WEIGHT: 59.0 lbs.

NAME	DATE
DRAWN: <i>Cobey</i>	11-19-14
CHECKED: <i>R...</i>	11-20-14
Q.A.	
MFG APPR: <i>R...</i>	11-21-14
SCALE: 1:10	
DO NOT SCALE DRAWING	

**THE SUBSEA COMPANY** THE SUBSEA COMPANY INC

SIZE: **B** TITLE: VACUUM PUMP ASSEMBLY WITH CASE, 10 CFM REV: **C1**

DWG. NO. TSC-01179-GA SHEET 1 OF 1