

REVISIONS				
REV.	DESCRIPTION	ECO #	DATE	APPROVED
B1	RELEASE	2017-066	7/10/17	

TSC-02279-UV-SK SPARES KIT, FLUID FILTRATION PANEL WITH PUMP & UV		
PART NUMBER	DESCRIPTION	QTY.
SE-1847	FILTER, 12 MICRON, 4-1/2"X30", MELT BLOWN POLYPROPYLENE	1
SE-1846	FILTER, 3 MICRON, 4-1/2"X30", MELT BLOWN POLYPROPYLENE	1
SE-1210	FUSE, TIME LAG, 30A, CLASS CC, 600/300 VAC/VDC	2
SE-1288	FUSE, 5 x 20 mm CARTRIDGE, 5 AMPS, 250 VAC FAST ACTING	2

TSC-02279-UV-RK REPAIR KIT, FLUID FILTRATION PANEL WITH PUMP & UV		
PART NUMBER	DESCRIPTION	QTY.
TSC-02279-UV-SK	SPARES KIT, FLUID FILTRATION PANEL WITH PUMP & UV	1
SE-1834	LAMP, UV, 110 WATT, 100-250 VAC, FOR VP950 UV SYSTEM	1
SE-1835	SLEEVE, QUARTZ, FOR VP950 UV SYSTEM	1
SE-1320	O-RING, SEAL, QUARTZ SLEEVE REPLACEMENT TUBE, UV LAMP	2
SE-0832-1	GAUGE, DIFFERENTIAL, FILTER COND., W/ MOUNTING BASE	1

ICM ACCESSORIES:

TSC-01967 ICM FLUSHING KIT WITH HAND PUMP
 SE-1877 IN-LINE CONTAMINATION MONITOR, USB INTERFACE

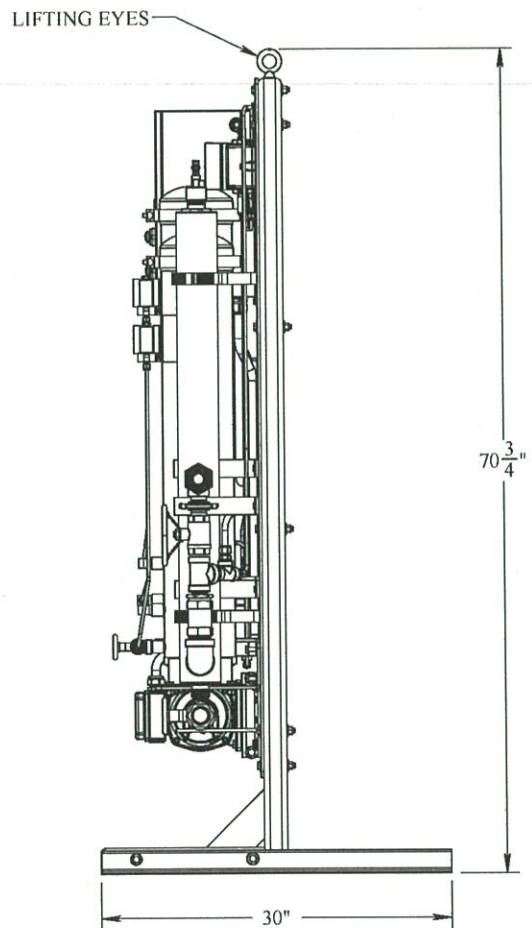
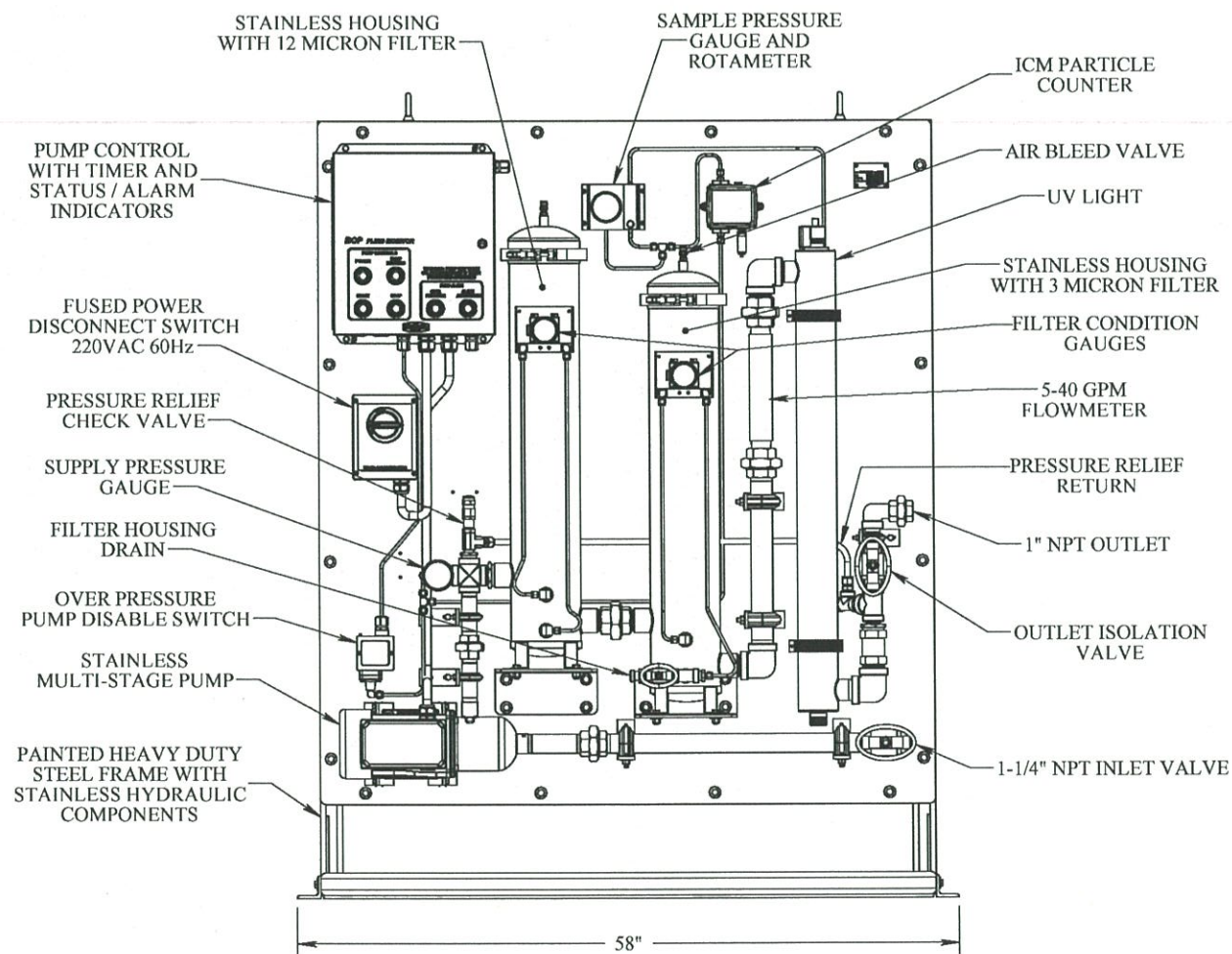
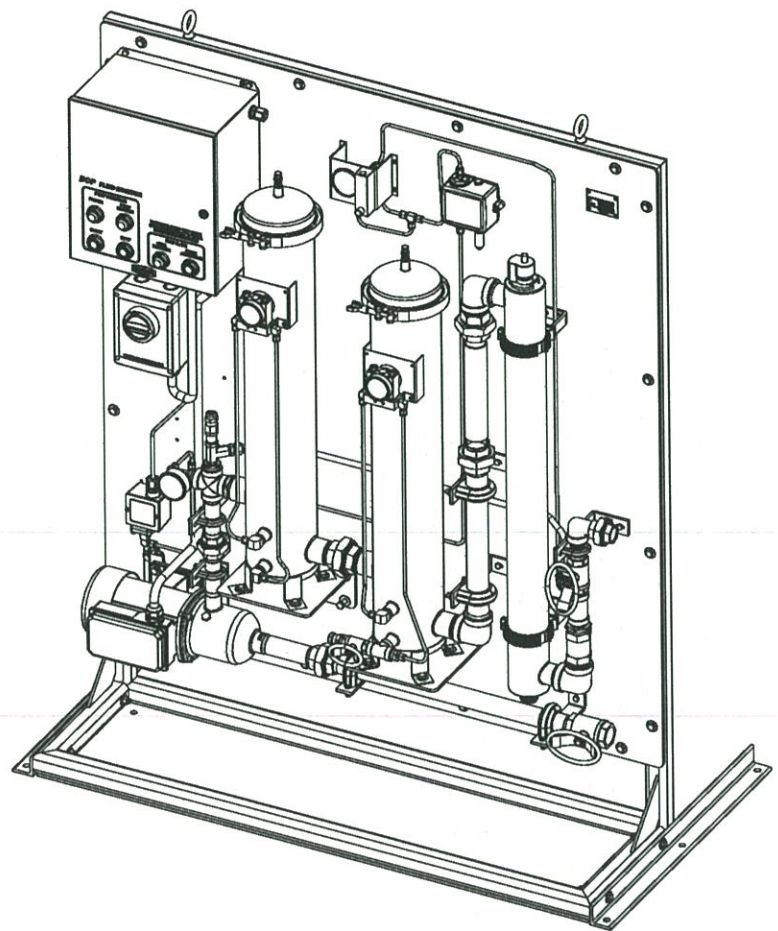
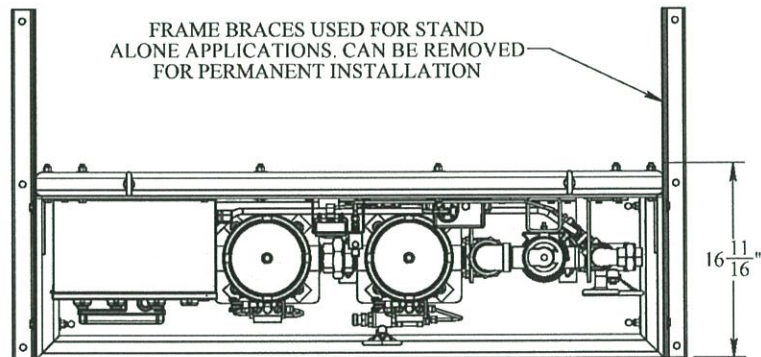

FILTRATION PANEL WITH PUMP, UV AND ICM

- PUMP CONTROL WITH TIMER AND STATUS / ALARM INDICATORS
- FUSED POWER DISCONNECT SWITCH, 220VAC, SINGLE PHASE, 60Hz
- MULTI-STAGE STAINLESS STEEL PUMP
- DUAL FILTER HOUSINGS, 12 MICRON PRE FILTER, 3 MICRON POST FILTER
- FILTER CONDITION GAUGES
- 5 - 40 GPM FLOWMETER
- SUPPLY PRESSURE GAUGE
- OVER PRESSURE BYPASS CHECK VALVE
- OVER PRESSURE PUMP DISABLE SWITCH
- UV LIGHT (ULTRAVIOLET GERMICIDAL IRRADIATION)
- SAMPLE PRESSURE GAUGE AND ROTAMETER
- ICM PARTICLE COUNTER (ISO / NAS)
- 1-1/4" NPT INLET CONNECTION, 1" NPT OUTLET CONNECTION
- 100 PSI MAXIMUM WORKING PRESSURE
- PAINTED HEAVY DUTY FRAME WITH STAINLESS HYDRAULIC COMPONENTS

PROPRIETARY AND CONFIDENTIAL:
 THE INFORMATION CONTAINED IN THIS DRAWING IS THE SOLE PROPERTY OF THE SUBSEA COMPANY INC. ANY REPRODUCTION IN PART OR AS A WHOLE WITHOUT THE WRITTEN PERMISSION OF THE SUBSEA COMPANY INC IS PROHIBITED.

3RD ANGLE PROJECTION

INTERPRET GEOMETRIC TOLERANCING PER: ASME Y14.5

WORKMANSHIP STANDARD PER WI 751-001

UNLESS OTHERWISE SPECIFIED:
 ALL DIMENSIONS ARE IN INCHES

WEIGHT: 784.26 LBS.

	NAME	DATE
DRAWN	<i>JS</i>	7-31-17
CHECKED	<i>AC</i>	7-31-17
APPROVED	<i>Rm</i>	7-31-17

THE SUBSEA COMPANY THE SUBSEA COMPANY INC

SIZE: **B** TITLE: FLUID FILTRATION PANEL, WITH PUMP, UV, & ICM REV: **B1**

DWG. NO. TSC-02279-UV-ICM-GA SHEET 1 OF 1