

REVISIONS					ITEM NO.	PART NUMBER	DESCRIPTION	QTY.
REV.	DESCRIPTION	ECO #	DATE	APPROVED	10	TSC-01960	PUMP SKID ASSEMBLY, BOP FLUID FILTRATION	1
A1	RELEASE	2017-038	4/4/2017	CNB	20	TSC-02312	BOP FLUID FILTRATION PANEL	1

PUMP SPECS:

- 1-1/2 HP, 230V, 60 Hz SINGLE PHASE
- 33 GPM
- 1-1/4" NPT INLET x 1" NPT OUTLET
- MANUAL MOTOR STARTER
- INLET ISOLATION VALVES

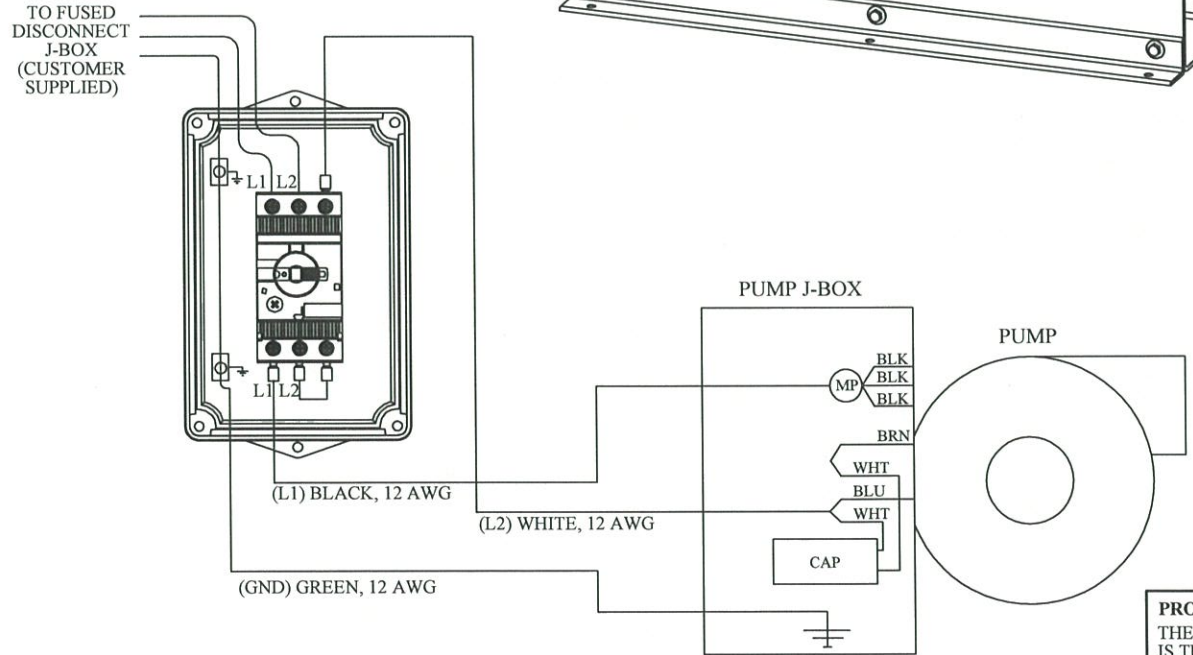
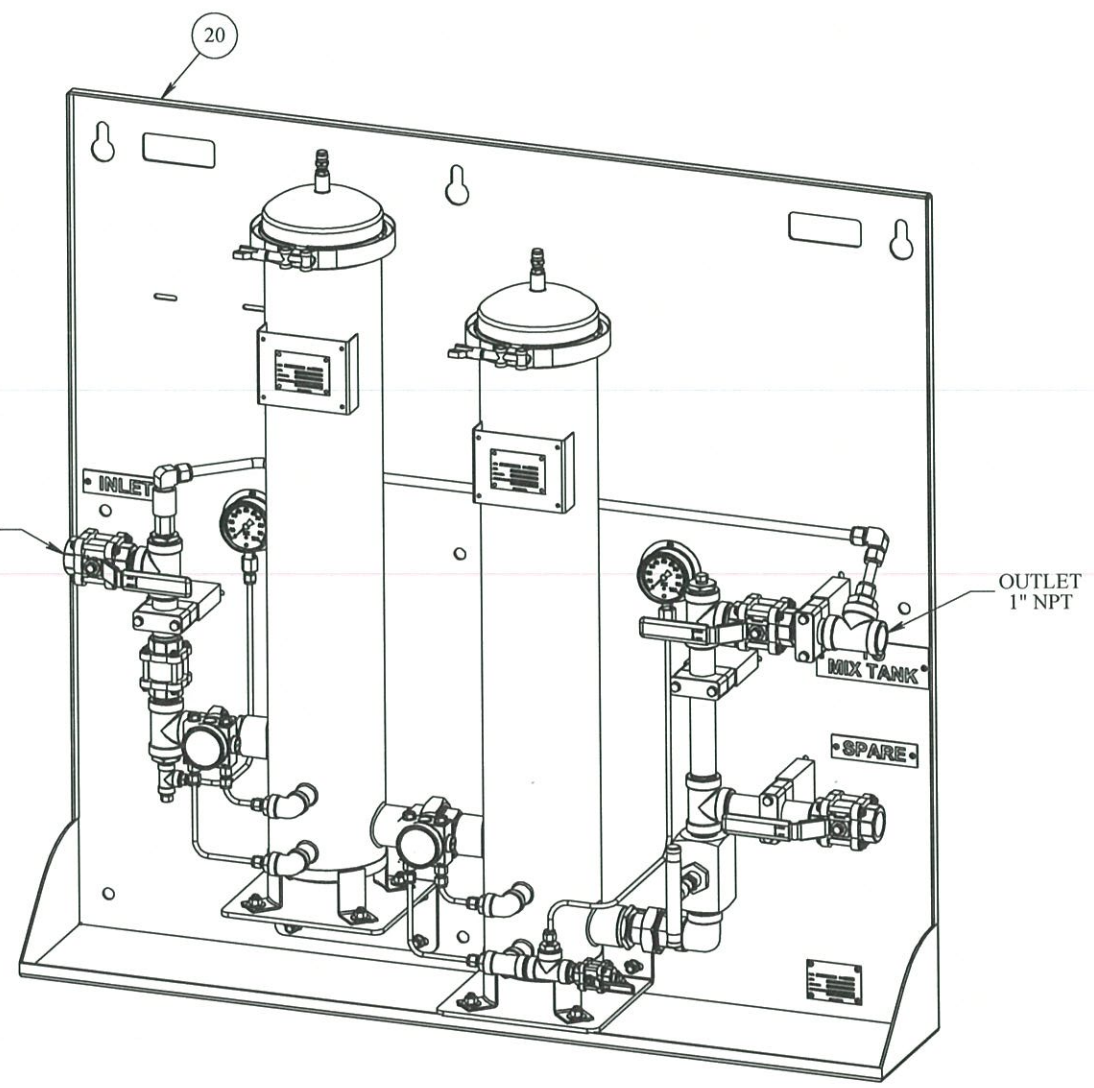
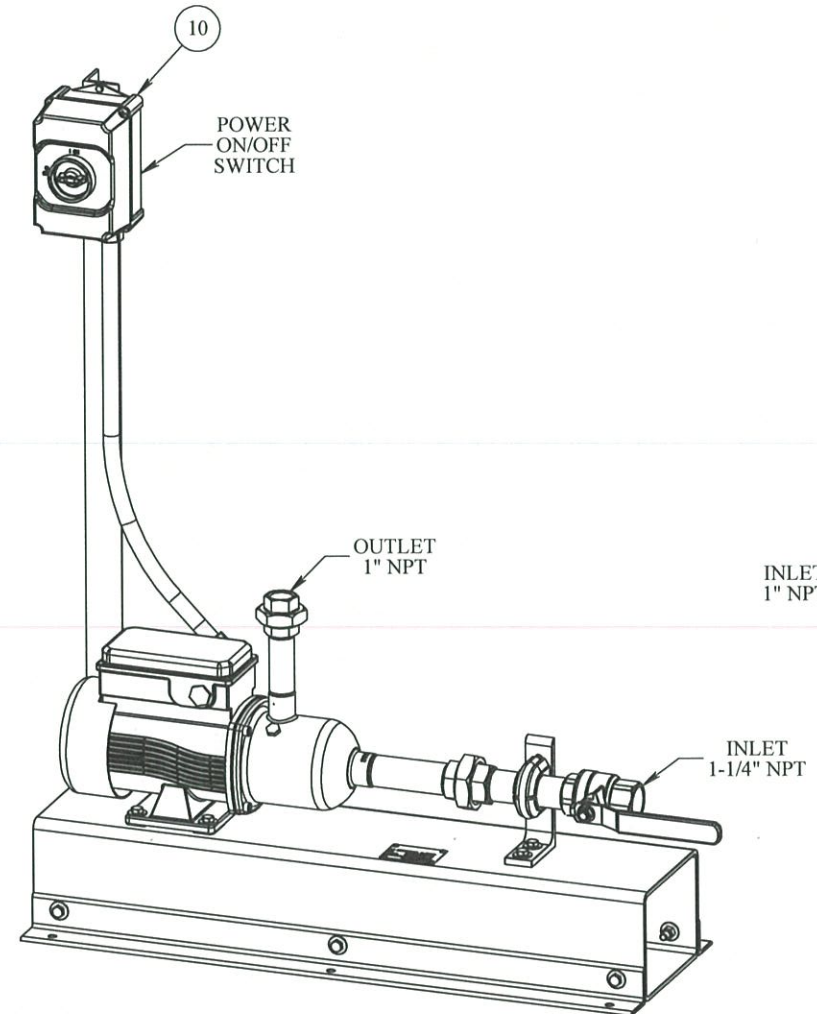

FILTRATION SPECS:

- TWO 4" x 30" STAINLESS FILTER HOUSINGS
- CHECK VALVE AND ISOLATION VALVES
- GAUGES AND FILTER GAUGES
- THROTTLE VALVE
- IN-LINE CONTAMINATION MONITOR CAN BE ADDED
- 1" NPT INLET AND OUTLETS

PROPRIETARY AND CONFIDENTIAL:
 THE INFORMATION CONTAINED IN THIS DRAWING IS THE SOLE PROPERTY OF THE SUBSEA COMPANY INC. ANY REPRODUCTION IN PART OR AS A WHOLE WITHOUT THE WRITTEN PERMISSION OF THE SUBSEA COMPANY INC IS PROHIBITED.

3RD ANGLE PROJECTION:

INTERPRET GEOMETRIC TOLERANCING PER: ASME Y14.5

WORKMANSHIP STANDARD PER W1 751-001

UNLESS OTHERWISE SPECIFIED: ALL DIMENSIONS ARE IN INCHES

NAME	DATE
DRAWN: CREL	4-4-17
CHECKED: [Signature]	4-5-17
APPROVED: [Signature]	4-5-17

THE SUBSEA COMPANY THE SUBSEA COMPANY INC

SIZE: **B** TITLE: BOP FLUID FILTRATION PANEL WITH FREE STANDING PUMP REV: **A1**

DWG. NO. TSC-02312-PUMP-GA SHEET 1 OF 1