

REVISIONS					ITEM NO.	PART NUMBER	DESCRIPTION	QTY.
REV.	DESCRIPTION	ECO #	DATE	APPROVED	10	TSC-00321-4	MUX CLAMP BASE ASSEMBLY, 2.95" LENGTH	1
A1	RELEASE	2013-511	12/19/2013	CJB	20	TSC-01306	MUX CLAMP, DGD, 2-HOLE, 1.12" x 1/72"	1

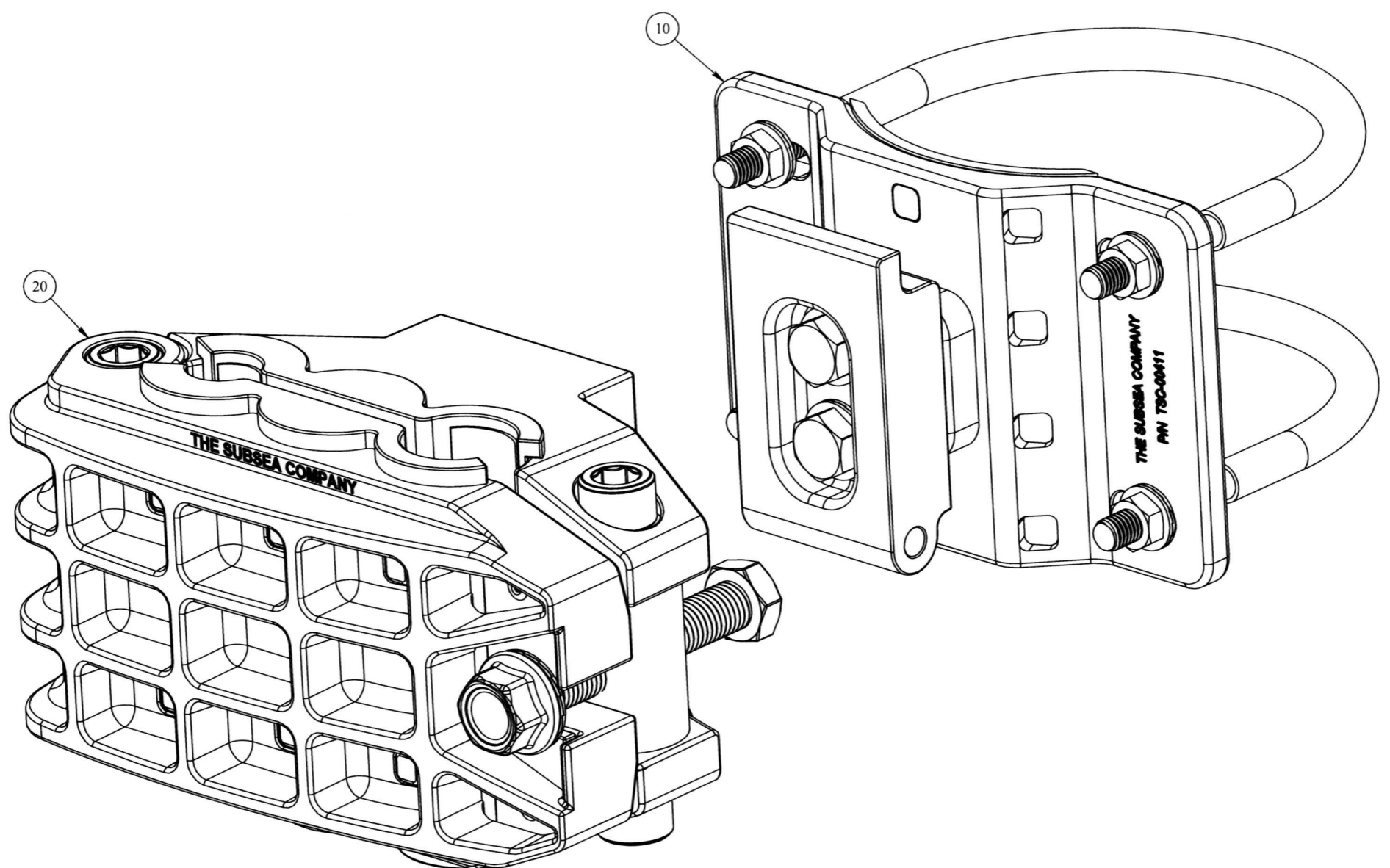

PROPRIETARY AND CONFIDENTIAL:
 THE INFORMATION CONTAINED IN THIS DRAWING IS THE SOLE PROPERTY OF THE SUBSEA COMPANY INC. ANY REPRODUCTION IN PART OR AS A WHOLE WITHOUT THE WRITTEN PERMISSION OF THE SUBSEA COMPANY INC IS PROHIBITED.

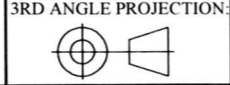

INTERPRET GEOMETRIC TOLERANCING PER: ASME Y14.5

WORKMANSHIP STANDARD PER WI 751-001
 UNLESS OTHERWISE SPECIFIED: ALL DIMENSIONS ARE IN INCHES
 WEIGHT: 31.97 lbs.

NAME	DATE
COEG	12-20-13
CHEKED	12-20-13
Q.A.	CATES 12-14-13
MFG APPR.	Rg 12-20-13

SCALE: 1:8
 DO NOT SCALE DRAWING

		THE SUBSEA COMPANY INC	
SIZE	TITLE:	REV	
B	MUX CLAMP ASSEMBLY, DGD CLAMP TSC-01306, BASE TSC-00321-4	A1	
DWG. NO.	TSC-01318		SHEET 1 OF 1