

REVISIONS				
REV.	DESCRIPTION	ECO #	DATE	APPROVED
A1	RELEASE	2019-039	4/17/2019	<i>GNB</i>

STAB SHOWN INSTALLED INTO RECEPTACLE WITH J-LOCK

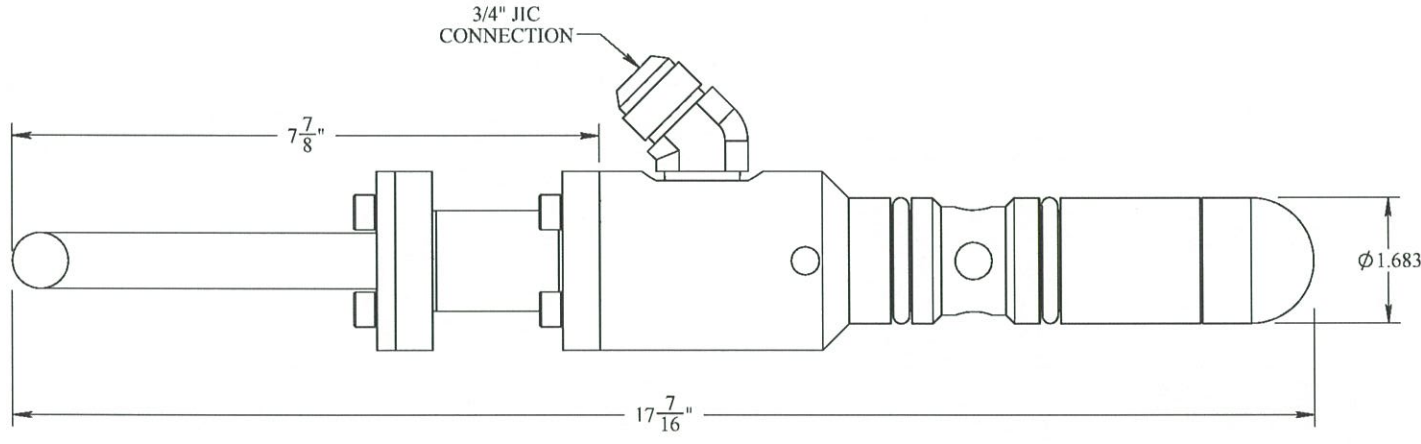

3/4" JIC CONNECTION

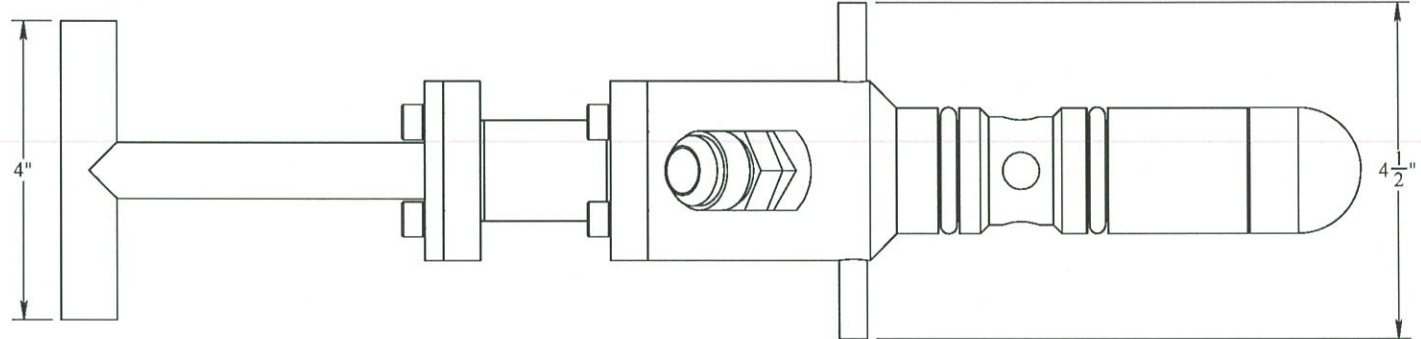
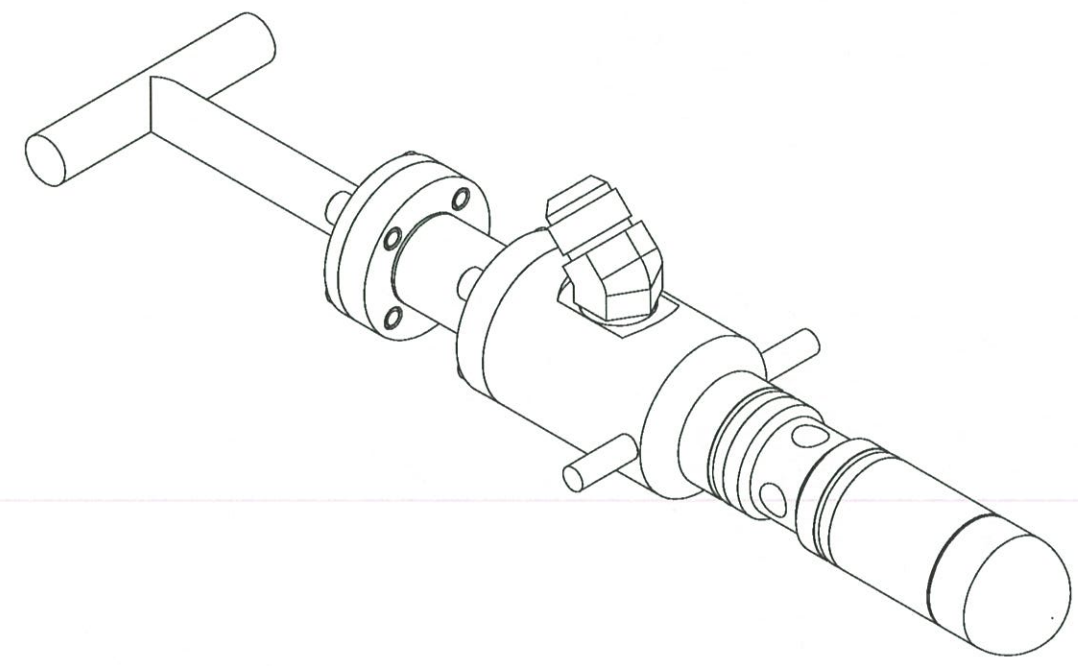
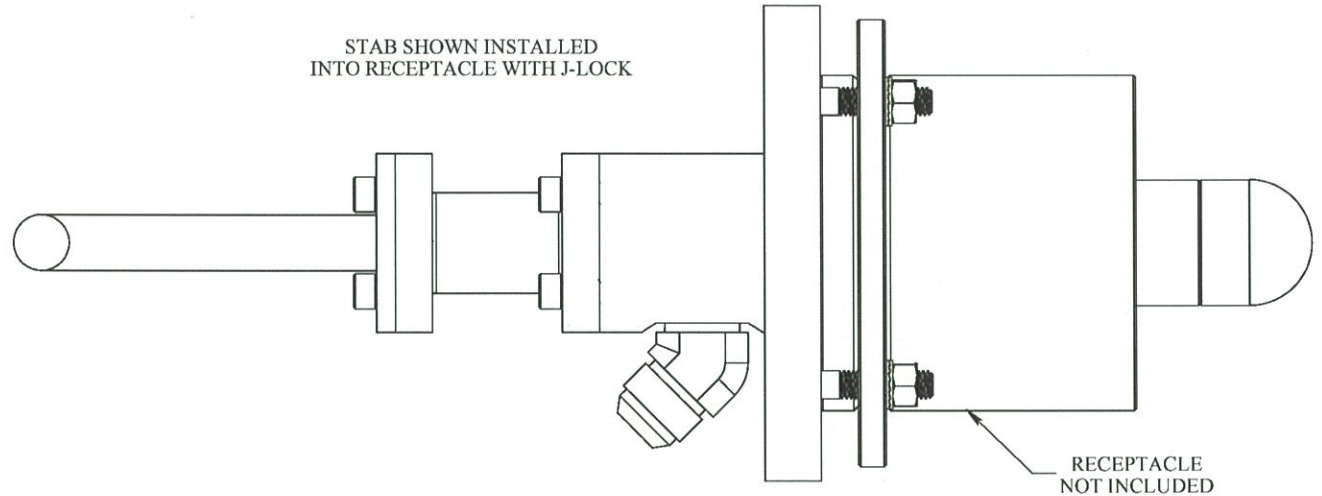
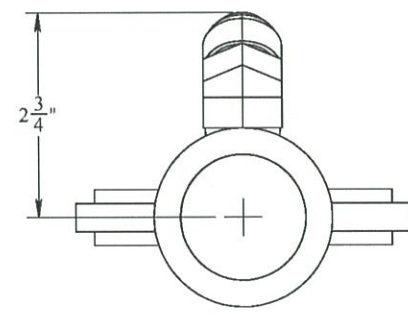

- NOTES:
- MATERIAL OF CONSTRUCTION:
 - MAIN BODY IS NITRONIC 60
 - HANDLE IS 316 STAINLESS STEEL
 - HANDLE FLEX JOINT
 - STAB NOSE IS DELRIN
 - HARDWARE IS 316 STAINLESS STEEL
 - DESIGNED TO API 17H TYPE B STANDARDS
 - FLUID CONNECTION IS 3/4" JIC OUTLET SCREWED INTO 3/4" NPT
 - WEIGHT: 9 LBS
 - NOTE: THERE IS NO STANDARD FOR THE J-LOCK

PROPRIETARY AND CONFIDENTIAL:
 THE INFORMATION CONTAINED IN THIS DRAWING IS THE SOLE PROPERTY OF THE SUBSEA COMPANY INC. ANY REPRODUCTION IN PART OR AS A WHOLE WITHOUT THE WRITTEN PERMISSION OF THE SUBSEA COMPANY INC IS PROHIBITED.

3RD ANGLE PROJECTION

INTERPRET GEOMETRIC TOLERANCING PER: ASME Y14.5

WORKMANSHIP STANDARD PER WI 751-001

UNLESS OTHERWISE SPECIFIED:
 ALL DIMENSIONS ARE IN INCHES

WEIGHT: 9.01 LBS.

	NAME	DATE
DRAWN	<i>GREG</i>	4-17-19
CHECKED	<i>AC</i>	4-17-19
APPROVED		

THE SUBSEA COMPANY THE SUBSEA COMPANY INC

SIZE	TITLE:	REV
B	HOT STAB ASSEMBLY, WITH J-LOCK	A1

DWG. NO. TSC-02611-GA SHEET 1 OF 1