

REVISIONS				
REV.	DESCRIPTION	ECO #	DATE	APPROVED
A1	RELEASE	2019-069	6/21/2018	
A4	EDITED DESCRIPTION & NOTES	2023-070	10/11/2023	

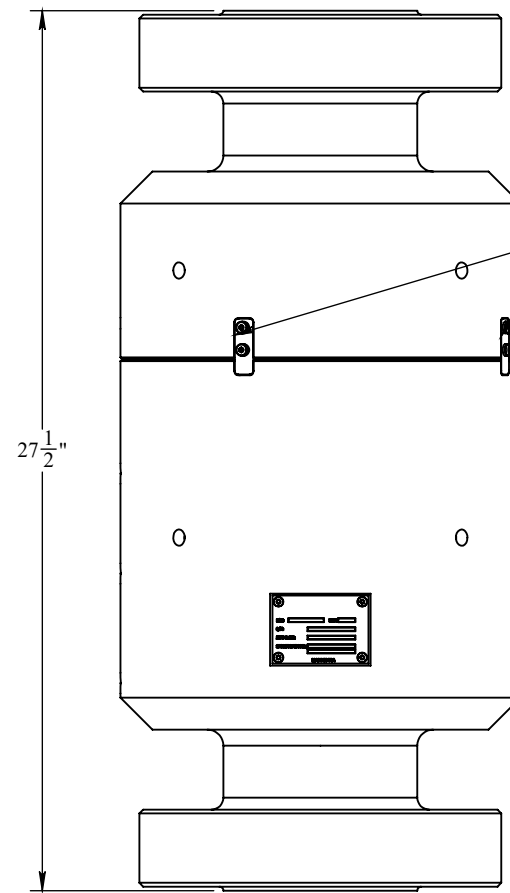
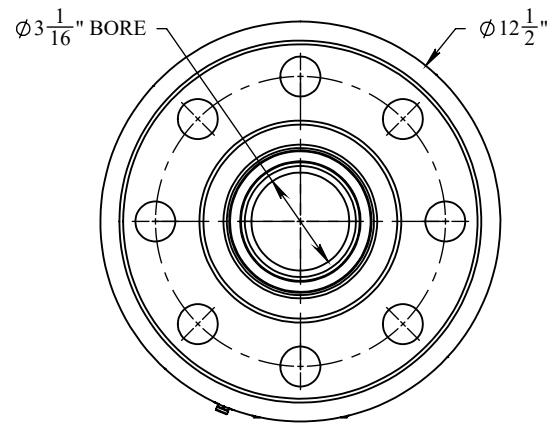

LEAKAGE INDICATING PORT
(1 ON BACKSIDE)

ANTI-ROTATION TABS
(2 ON BACKSIDE)

GREASE PORTS
(3 ON BACKSIDE)

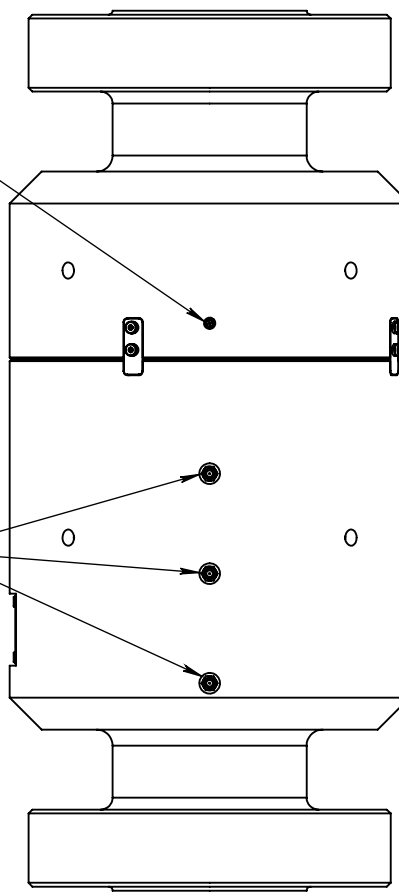

ACCESSORIES

PART NO.	DESCRIPTION	QTY.
SE-1112	GREASE, SYNTHETIC, INDUSTRIAL, LC 2, NLGI GRADE 1.5	28 oz.
SE-2151	GASKET, BX-154, 316SS	2

SPARE PARTS

PART NO.	DESCRIPTION	QTY.
TSC-02455-SK	KIT, SEAL	1
TSC-02455-BK	KIT, BALL BEARING	1

NOTES:

- DESIGNED FOR CHOKE AND KILL LINES
- MEET NACE MR0175 FOR H2S SERVICE
- PRESSURE CONTAINING PARTS ARE BUILT FROM STAINLESS STEEL
- WORKING PRESSURE - 15K PSI MAX
- TESTED AT 1.5 TIMES WORKING PRESSURE
- API 6A 3-1/16 BX154 15,000 FLANGE
- ONE PRIMARY SEAL AND TWO BACK UP SEALS
- SIX GREASE PORTS
- TWO LEAKAGE INDICATING PORTS
- DESIGNED WITH HEAVY DUTY BEARINGS FOR HIGH LOAD SERVICE

STANDARDS AND REGULATIONS

- API 6A-SPECIFICATIONS FOR VALVES AND WELL-HEAD EQUIPMENT
- API 16C-SPECIFICATIONS FOR CHOKE AND KILL SYSTEMS.
- API 17D-DESIGN AND OPERATION OF SUBSEA PRODUCTION SYSTEM
- ABS CLASSIFICATION OF DRILLING SYSTEM-AVAILABLE

PROPRIETARY AND CONFIDENTIAL:
THE INFORMATION CONTAINED IN THIS DRAWING IS THE SOLE PROPERTY OF THE SUBSEA COMPANY INC. ANY REPRODUCTION IN PART OR AS A WHOLE WITHOUT THE WRITTEN PERMISSION OF THE SUBSEA COMPANY INC IS PROHIBITED.

3RD ANGLE PROJECTION:

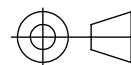

INTERPRET GEOMETRIC TOLERANCING PER: ASME Y14.5

WORKMANSHIP STANDARD PER WI 751-001

UNLESS OTHERWISE SPECIFIED:
ALL DIMENSIONS ARE IN INCHES

WEIGHT: 628.85 LBS.

	NAME	DATE
DRAWN	TLC	10/11/2023
CHECKED	AC	10/11/2023
APPROVED	TAC	10/11/2023



SIZE	TITLE:	REV
B	SWIVEL, CHOKE AND KILL, 15K WP, API 6A 3-1/16" BX154 15K FLANGE X FLANGE	A4

DWG. NO. TSC-02455-GA

SHEET 1 OF 1