

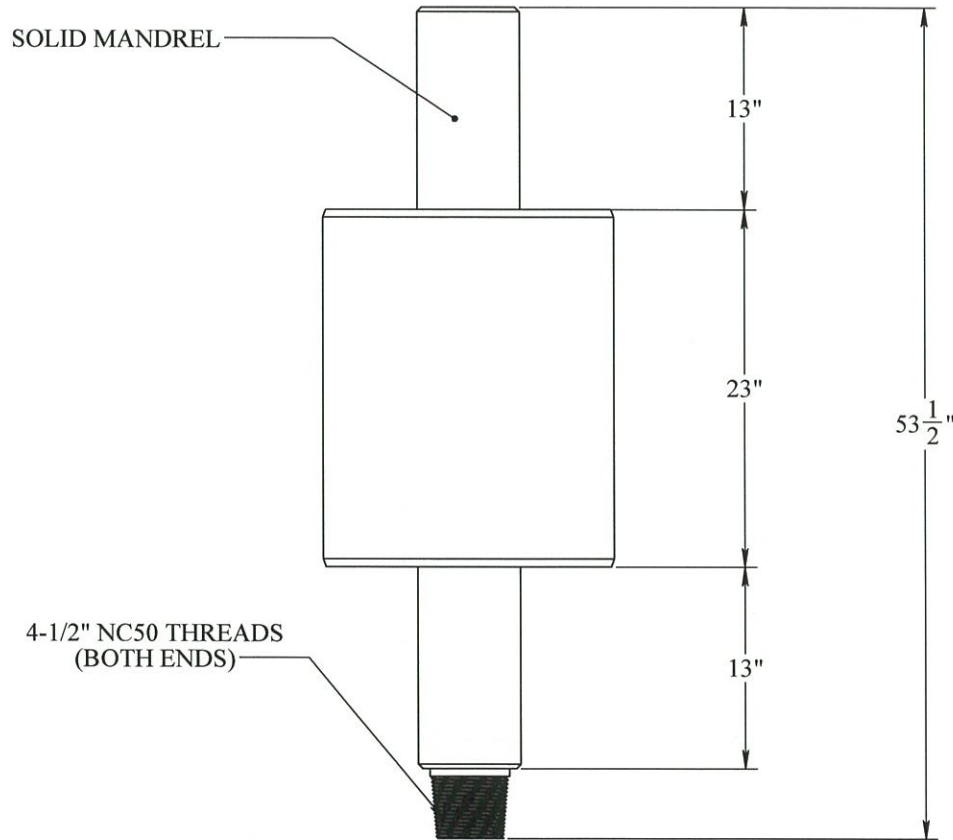

REVISIONS				
REV.	DESCRIPTION	ECO #	DATE	APPROVED
A1	RELEASE	2014-169	5/27/2014	<i>GRB</i>

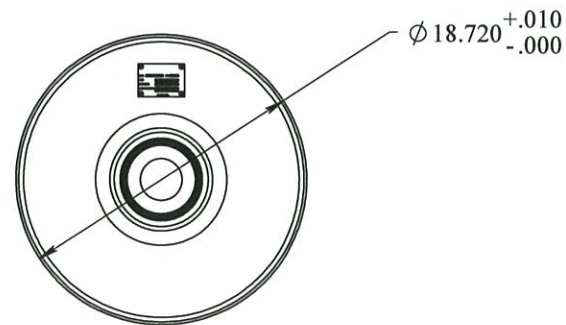

DRIFT FEATURES

1. OUTSIDE DIAMETER 18.720 +.010-.000
2. 4-1/2" NC50 BOX x PIN
3. DESIGNED IAW WITH API SPECIFICATION 7, MEETS OR EXCEEDS REQUIREMENTS OF TABLE 7
4. MAKE-UP WITH CHAIN TONGS
5. WORKING LOAD 10,000 LBS
6. PULL TESTED TO 15,000 LBS
7. APPROXIMATE WEIGHT: 1083 LBS
8. MILD STEEL CONSTRUCTION (36 KSI)
9. DRIFT IS DESIGNED FOR SURFACE TESTING ONLY

PROPRIETARY AND CONFIDENTIAL:
 THE INFORMATION CONTAINED IN THIS DRAWING IS THE SOLE PROPERTY OF THE SUBSEA COMPANY INC. ANY REPRODUCTION IN PART OR AS A WHOLE WITHOUT THE WRITTEN PERMISSION OF THE SUBSEA COMPANY INC IS PROHIBITED.

3RD ANGLE PROJECTION:

INTERPRET GEOMETRIC TOLERANCING PER: ASME Y14.5

WORKMANSHIP STANDARD PER WI 751-001

UNLESS OTHERWISE SPECIFIED: ALL DIMENSIONS ARE IN INCHES

	NAME	DATE
DRAWN	<i>BPS</i>	<i>5/27/14</i>
CHECKED	<i>GRB</i>	<i>6/10/14</i>
Q.A.	<i>R...</i>	<i>6/11/14</i>
MFG APPR.	<i>T...</i>	<i>6/22/14</i>

 THE SUBSEA COMPANY INC	
SIZE B	TITLE: DRIFT, 18-3/4" API, 23" BODY 4-1/2" NC50 BOX x PIN
DWG. NO. TSC-02111-GA	REV A1
SHEET 1 OF 1	