

REVISIONS				
REV.	DESCRIPTION	ECO #	DATE	APPROVED
A1	RELEASE	2017-067	7/11/2017	

TSC-02279-ICM-SK SPARES KIT, FLUID FILTRATION PANEL WITH PUMP & ICM		
PART NUMBER	DESCRIPTION	QTY.
SE-1847	FILTER, 12 MICRON, 4-1/2"X30", MELT BLOWN POLYPROPYLENE	1
SE-1846	FILTER, 3 MICRON, 4-1/2"X30", MELT BLOWN POLYPROPYLENE	1
SE-1210	FUSE, TIME LAG, 30A, CLASS CC, 600/300 VAC/VDC	2
SE-1288	FUSE, 5 x 20 mm CARTRIDGE, 5 AMPS, 250 VAC FAST ACTING	2
SE-0832-1	GAUGE, DIFFERENTIAL, FILTER COND., W/ MOUNTING BASE	1

ICM ACCESSORIES:
TSC-01967 ICM FLUSHING KIT WITH HAND PUMP
SE-1877 IN-LINE CONTAMINATION MONITOR, USB INTERFACE

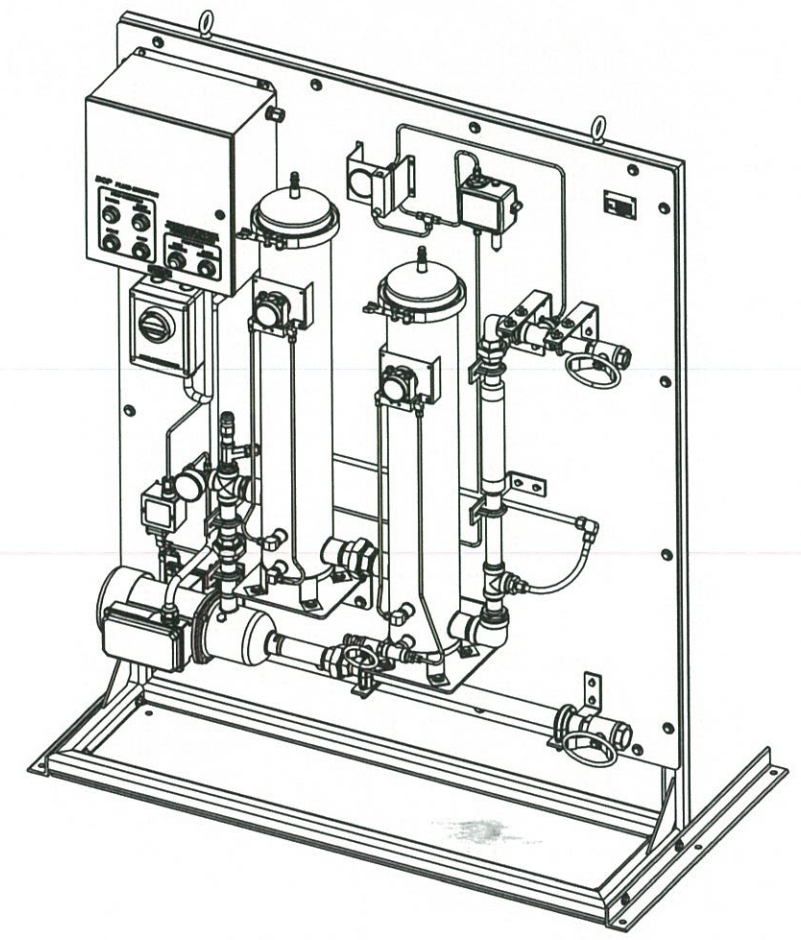
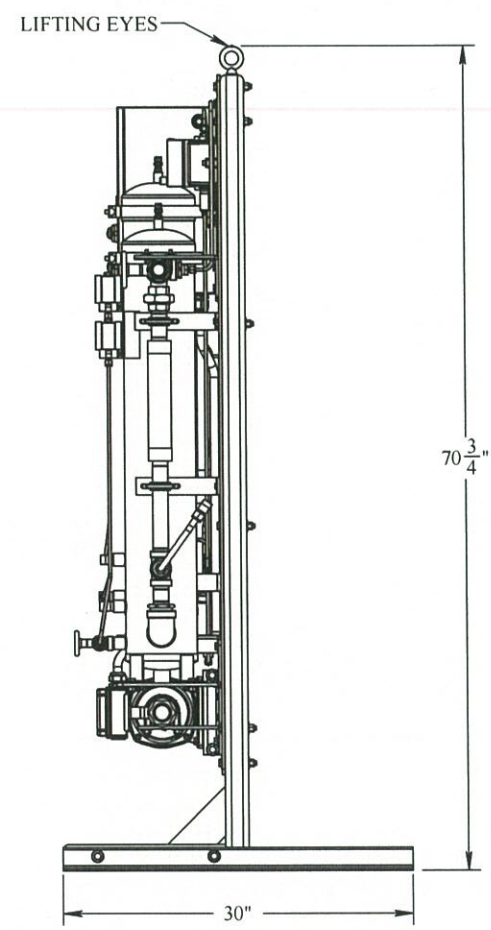
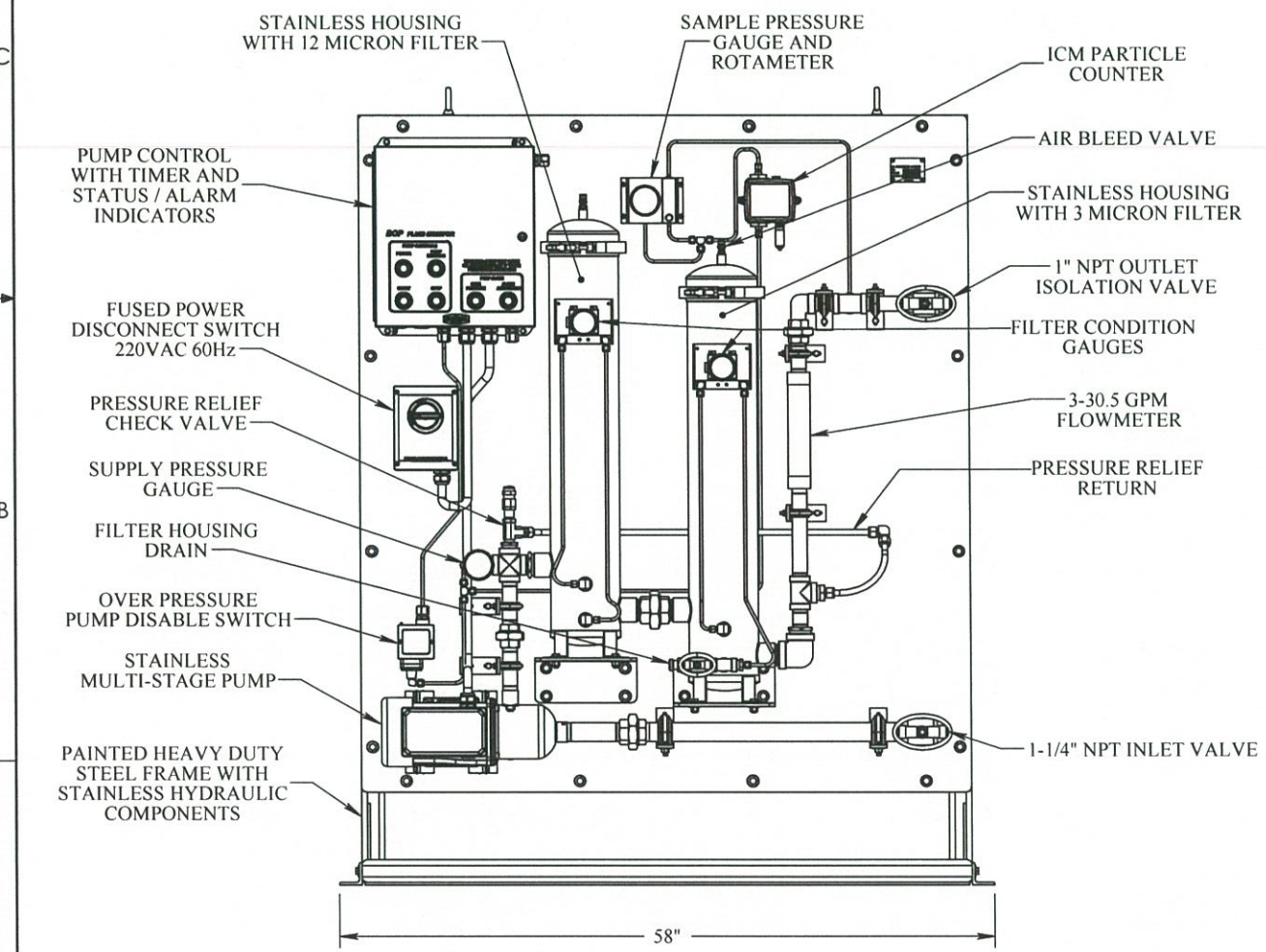
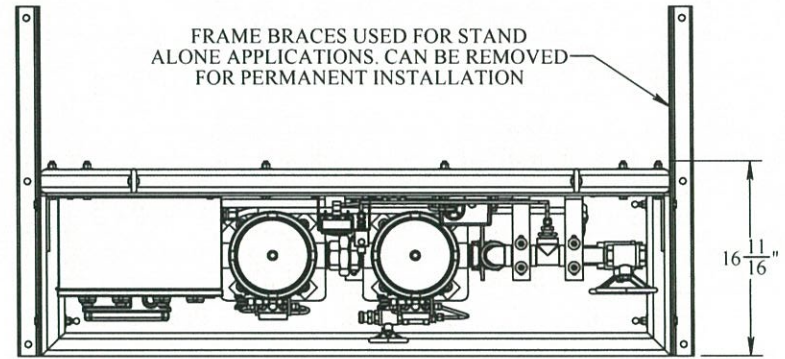

- FEATURES:**
- PUMP CONTROL WITH TIMER AND STATUS / ALARM INDICATORS
 - FUSED POWER DISCONNECT SWITCH, 220VAC, SINGLE PHASE, 60Hz
 - MULTI-STAGE STAINLESS STEEL PUMP
 - DUAL FILTER HOUSINGS, 12 MICRON PRE FILTER, 3 MICRON POST FILTER
 - FILTER CONDITION GAUGES
 - 3 - 30.5 GPM FLOWMETER
 - SUPPLY PRESSURE GAUGE
 - OVER PRESSURE BYPASS CHECK VALVE
 - OVER PRESSURE PUMP DISABLE SWITCH
 - SAMPLE PRESSURE GAUGE AND ROTAMETER
 - ICM PARTICLE COUNTER (ISO / NAS)
 - 1-1/4" NPT INLET CONNECTION, 1" NPT OUTLET CONNECTION
 - 100 PSI MAXIMUM WORKING PRESSURE
 - PAINTED HEAVY DUTY FRAME WITH STAINLESS HYDRAULIC COMPONENTS

PROPRIETARY AND CONFIDENTIAL:
THE INFORMATION CONTAINED IN THIS DRAWING IS THE SOLE PROPERTY OF THE SUBSEA COMPANY INC. ANY REPRODUCTION IN PART OR AS A WHOLE WITHOUT THE WRITTEN PERMISSION OF THE SUBSEA COMPANY INC IS PROHIBITED.

WORKMANSHIP STANDARD PER WI 751-001

UNLESS OTHERWISE SPECIFIED:
ALL DIMENSIONS ARE IN INCHES

WEIGHT: 768.59 LBS.

	NAME	DATE
DRAWN	COLEY	7-28-17
CHECKED	kg	7-31-17
APPROVED	km	7-31-17

THE SUBSEA COMPANY THE SUBSEA COMPANY INC

SIZE: **B** TITLE: FLUID FILTRATION PANEL, WITH PUMP, & ICM

DWG. NO. TSC-02279-ICM-GA

REV **A1** SHEET 1 OF 1

