

NOTES:
 1. SUITABLE FOR LUBRICATED WATER BASED SERVICE.
 2. MAX INLET PRESSURE - 5,000 PSI
 3. INCLUDES INTEGRATED PANEL MOUNTED, EIGHT CHANNEL, HIGH SPEED DATA ACQUISITION TEST MODULE, TSC-02024.

PROPRIETARY AND CONFIDENTIAL:
 THE INFORMATION CONTAINED IN THIS DRAWING IS THE SOLE PROPERTY OF THE SUBSEA COMPANY INC. ANY REPRODUCTION IN PART OR AS A WHOLE WITHOUT THE WRITTEN PERMISSION OF THE SUBSEA COMPANY INC IS PROHIBITED.

3RD ANGLE PROJECTION:



INTERPRET GEOMETRIC TOLERANCING PER: ASME Y14.5

WORKMANSHIP STANDARD PER WI 751-001

UNLESS OTHERWISE SPECIFIED:
 ALL DIMENSIONS ARE IN INCHES

WEIGHT: 2280 LBS

	NAME	DATE
DRAWN	GREG	12-10-15
CHECKED	COREY	
Q.A.		12-10-15
MFG./SALES		

 THE SUBSEA COMPANY INC		REV
SIZE	TITLE:	D1
B	TEST BENCH, MODULAR, FOR CAMERON HYDRAULIC COMPONENTS, INCLUDES CONFIGURED ADAPTER	
DWG. NO.	TSC-02023-GA	SHEET 1 OF 2

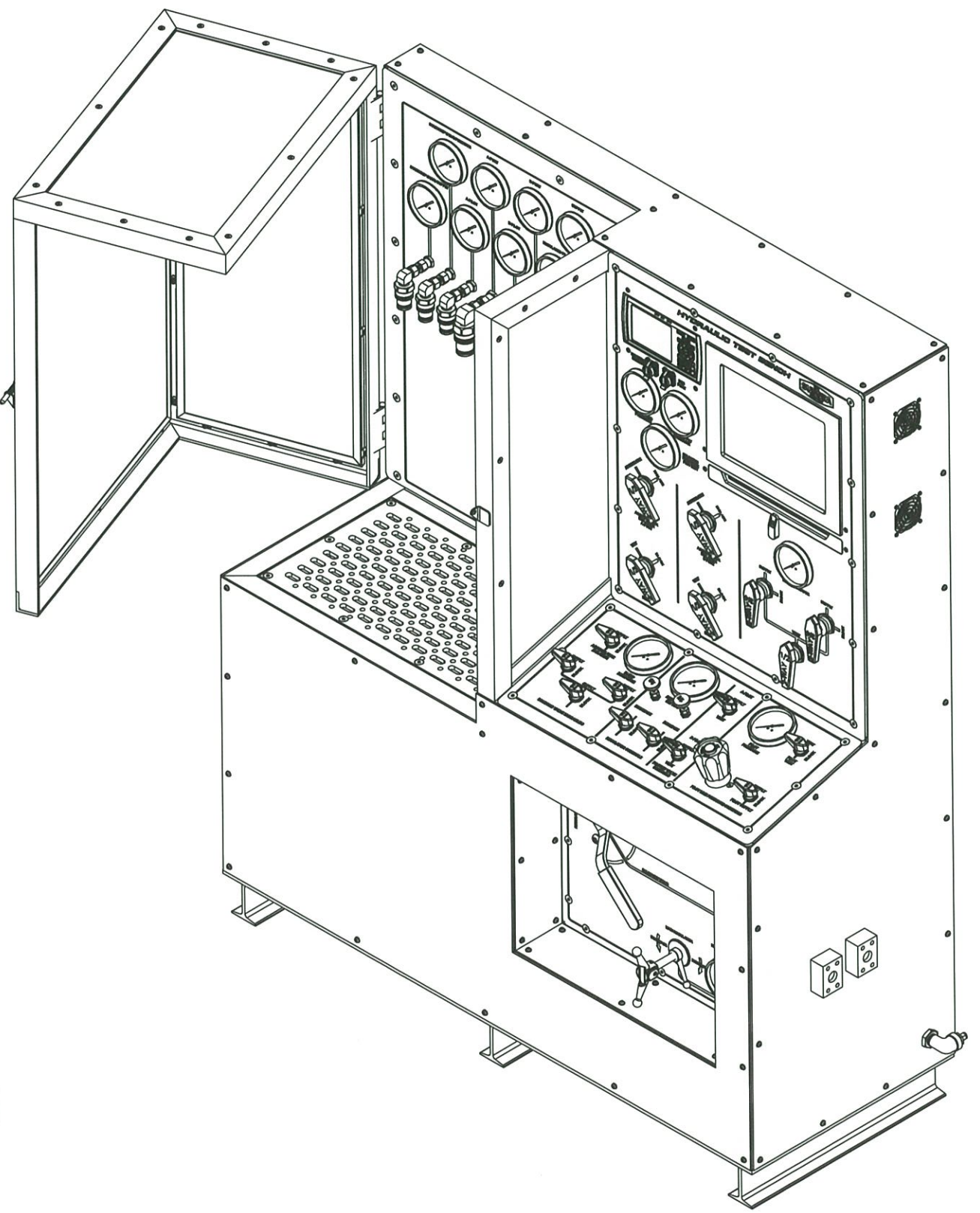
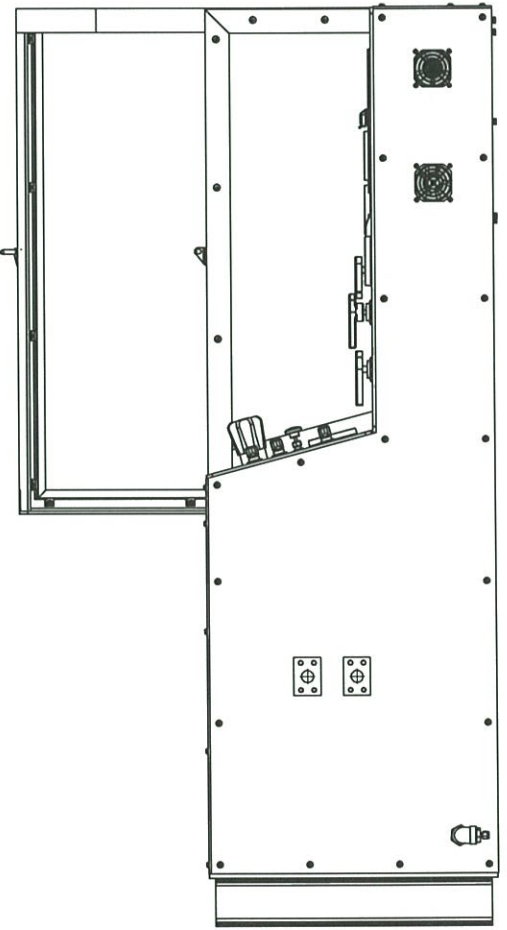
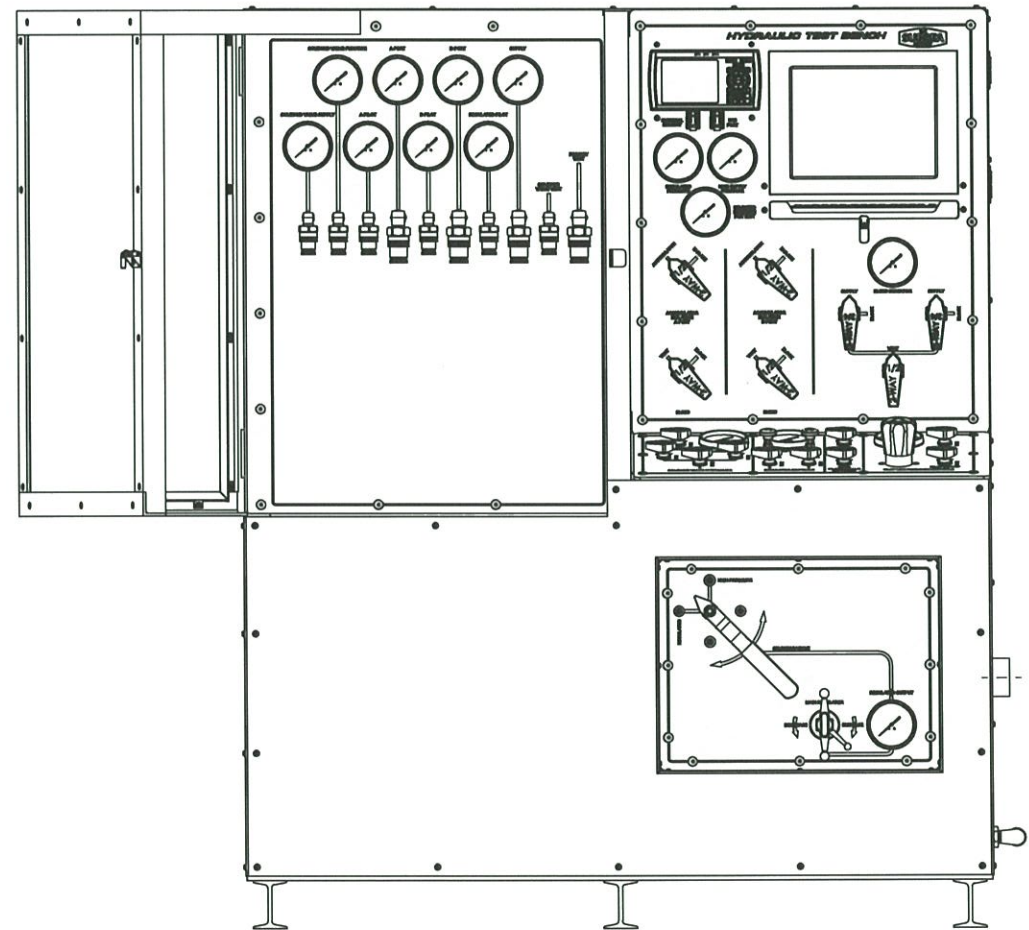
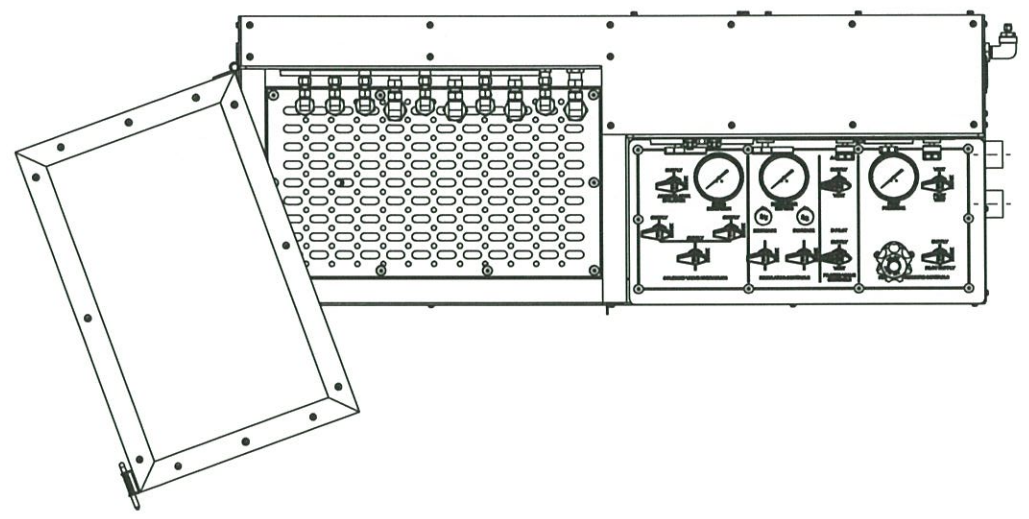

- NOTES:
 1. SUITABLE FOR LUBRICATED WATER BASED SERVICE.
 2. MAX INLET PRESSURE - 5,000 PSI
 3. INCLUDES INTEGRATED PANEL MOUNTED, EIGHT CHANNEL, HIGH SPEED DATA ACQUISITION TEST MODULE, TSC-02024.

PROPRIETARY AND CONFIDENTIAL:
 THE INFORMATION CONTAINED IN THIS DRAWING IS THE SOLE PROPERTY OF THE SUBSEA COMPANY INC. ANY REPRODUCTION IN PART OR AS A WHOLE WITHOUT THE WRITTEN PERMISSION OF THE SUBSEA COMPANY INC IS PROHIBITED.

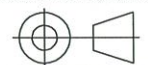
3RD ANGLE PROJECTION:



INTERPRET GEOMETRIC TOLERANCING PER: ASME Y14.5

WORKMANSHIP STANDARD PER WI 751-001

UNLESS OTHERWISE SPECIFIED:
 ALL DIMENSIONS ARE IN INCHES

WEIGHT: 2280 LBS

	NAME	DATE
DRAWN	GREG	12-10-15
CHECKED	GREG	12-10-16
Q.A.	JAG	12-10-15
MFG./SALES	JAG	12-10-15

 THE SUBSEA COMPANY INC		SIZE	TITLE:	REV
		B	TEST BENCH, MODULAR, FOR CAMERON HYDRAULIC COMPONENTS, INCLUDES CONFIGURED ADAPTER	D1
DWG. NO. TSC-02023-GA		SHEET 2 OF 2		