

REVISIONS				
REV.	DESCRIPTION	ECO #	DATE	APPROVED
X1	DRAFT		10/11/2023	

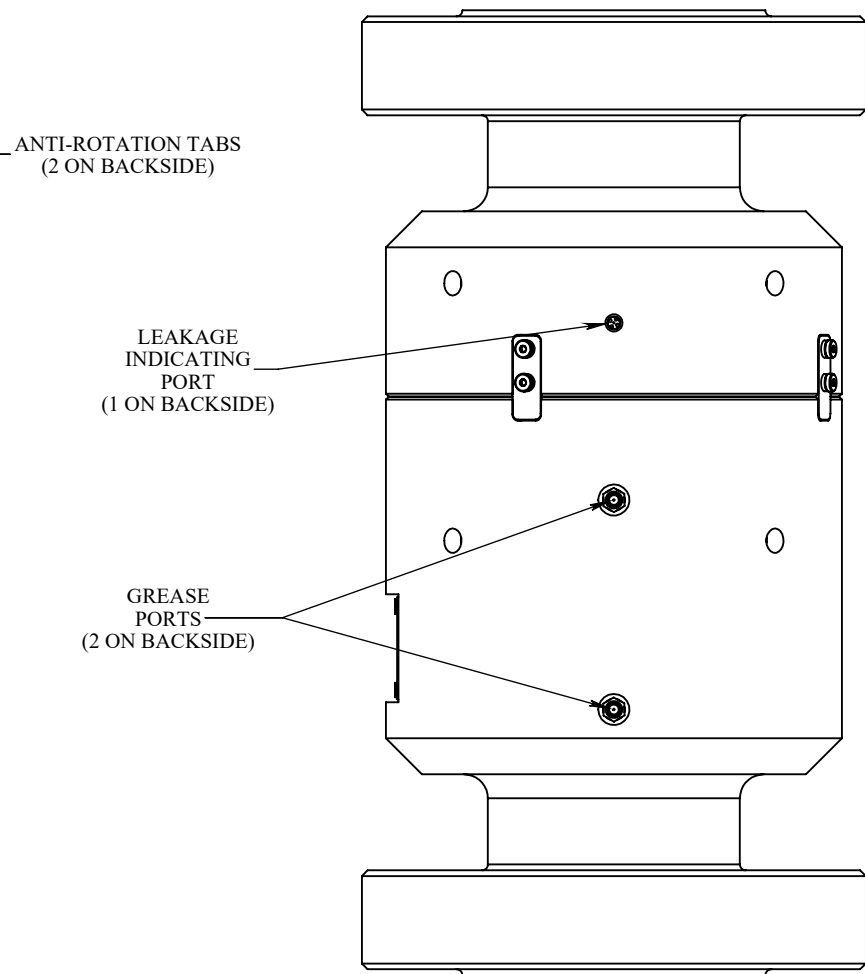
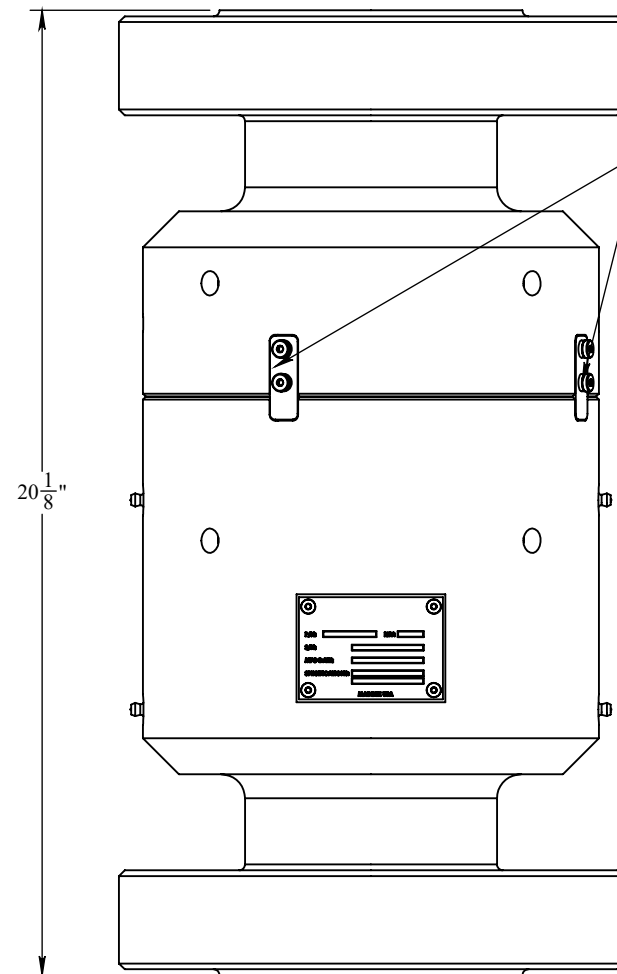
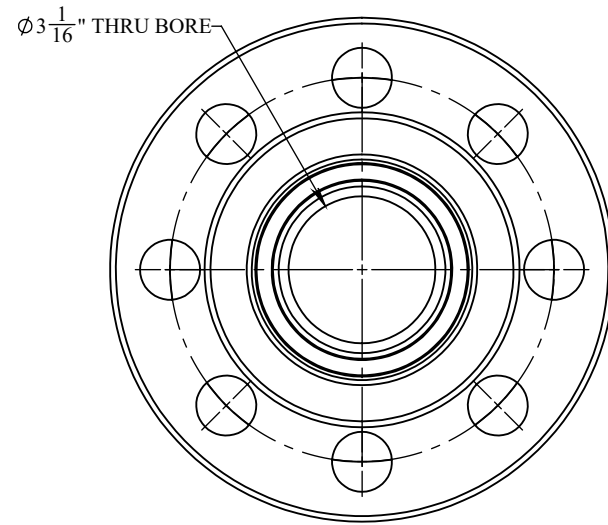

ACCESSORIES

PART NO.	DESCRIPTION	QTY.
SE-1112	GREASE, SYNTHETIC, INDUSTRIAL, LC 2, NLGI GRADE 1.5	28 oz.
SE-2151	GASKET, BX-154, 316SS	2

SPARE PARTS

PART NO.	DESCRIPTION	QTY.
TSC-02824-SK	KIT, SEAL	1
TSC-02824-BK	KIT, BALL BEARING	1

NOTES:

- DESIGNED FOR HYDRAULIC LINES
- MEET NACE MR0175 FOR H₂S SERVICE
- PRESSURE CONTAINING PARTS ARE BUILT FROM STAINLESS STEEL
- WORKING PRESSURE - 5K PSI MAX
- TESTED AT 1.5 TIMES WORKING PRESSURE
- API 6A 3-1/16 BX 154 10K FLANGE
- ONE PRIMARY SEAL AND TWO BACK UP SEALS
- FOUR GREASE PORTS
- TWO LEAKAGE INDICATING PORTS
- DESIGNED WITH HEAVY DUTY BEARINGS FOR HIGH LOAD SERVICE

STANDARDS AND REGULATIONS

- API 6A-SPECIFICATIONS FOR VALVES AND WELL-HEAD EQUIPMENT
- API 16D-SPECIFICATIONS FOR CONTROL SYSTEM FOR DRILLING WELL CONTROL EQUIPMENT
- ABS CLASSIFICATION OF DRILLING SYSTEM-AVAILABLE

PROPRIETARY AND CONFIDENTIAL:
THE INFORMATION CONTAINED IN THIS DRAWING IS THE SOLE PROPERTY OF THE SUBSEA COMPANY INC. ANY REPRODUCTION IN PART OR AS A WHOLE WITHOUT THE WRITTEN PERMISSION OF THE SUBSEA COMPANY INC IS PROHIBITED.

3RD ANGLE PROJECTION:

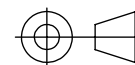

INTERPRET GEOMETRIC TOLERANCING PER: ASME Y14.5

WORKMANSHIP STANDARD PER WI 751-001

UNLESS OTHERWISE SPECIFIED: ALL DIMENSIONS ARE IN INCHES

WEIGHT: 157.38 LBS.

	NAME	DATE
DRAWN	TLC	10/11/2023
CHECKED	AC	10/11/2023
APPROVED	TAC	10/11/2023



THE SUBSEA COMPANY INC

SIZE	TITLE:	REV
B	SWIVEL, HYDRAULIC, 5K WP, API 6A 3-1/16" BX-154 10K FLANGE X FLANGE	X1

DWG. NO. TSC-02824-GA

SHEET 1 OF 1