

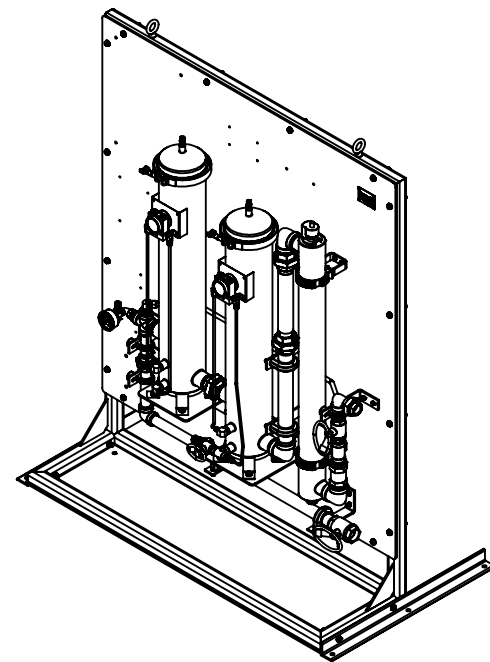

REVISIONS				
REV.	DESCRIPTION	ECO #	DATE	APPROVED
A1	RELEASE	2021-003	3/4/2021	

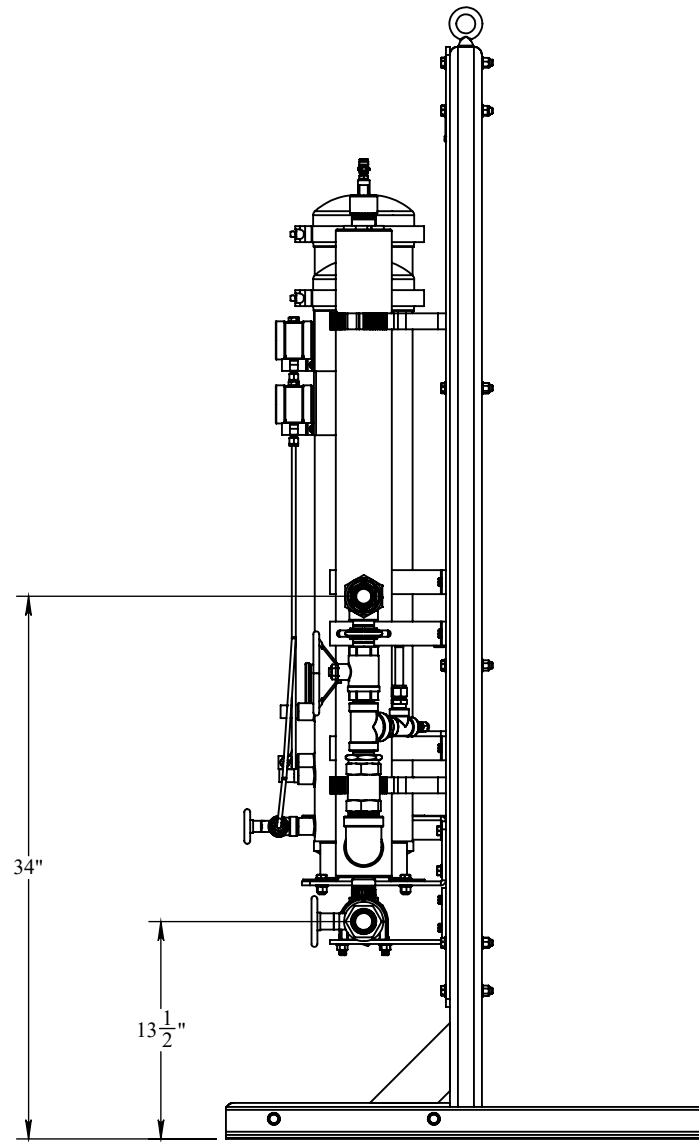
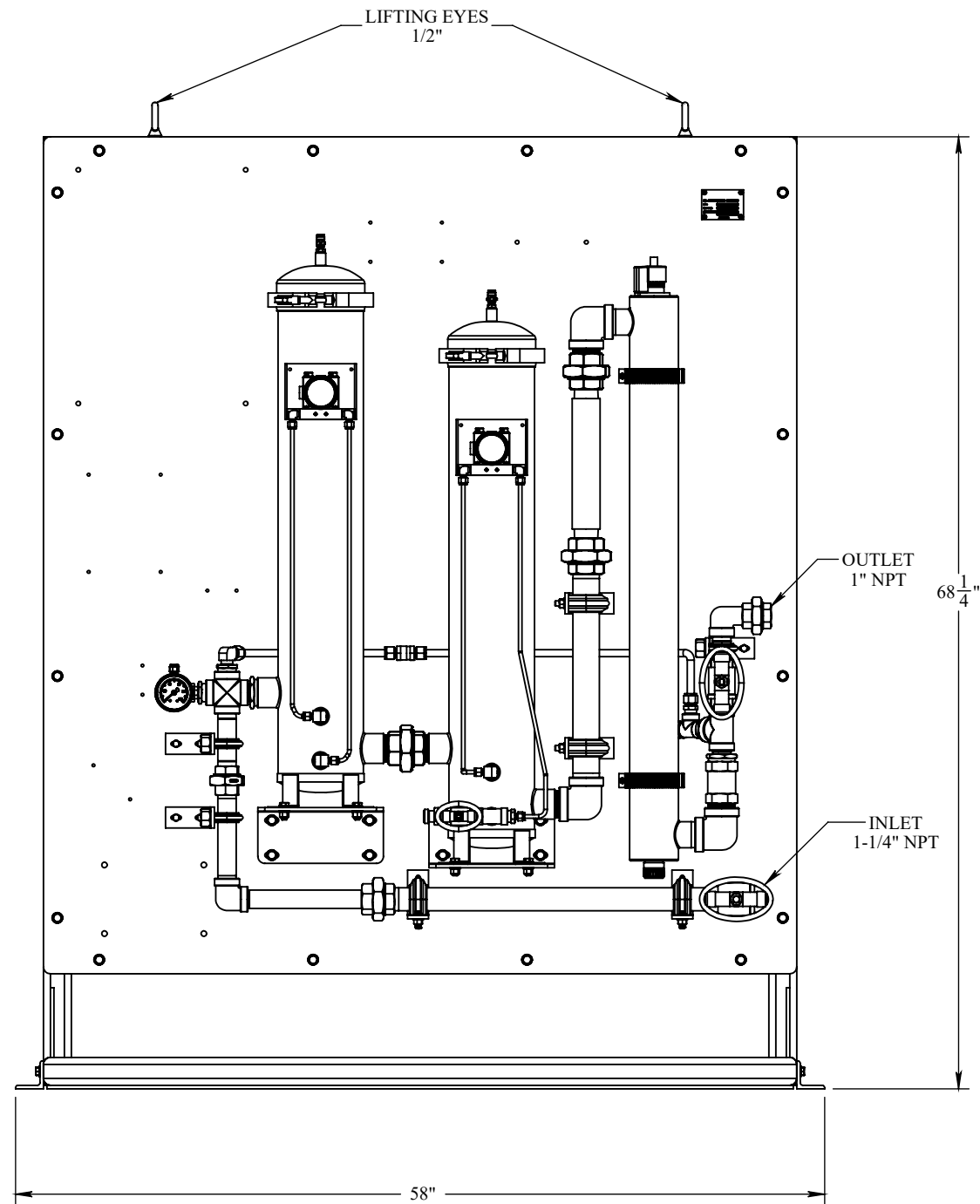

NOTES:  
 • ALL MEASUREMENTS SHOWN ARE ROUNDED TO THE NEAREST 1/4"

**PROPRIETARY AND CONFIDENTIAL:**  
 THE INFORMATION CONTAINED IN THIS DRAWING IS THE SOLE PROPERTY OF THE SUBSEA COMPANY INC. ANY REPRODUCTION IN PART OR AS A WHOLE WITHOUT THE WRITTEN PERMISSION OF THE SUBSEA COMPANY INC IS PROHIBITED.

3RD ANGLE PROJECTION:  

INTERPRET GEOMETRIC TOLERANCING PER: ASME Y14.5

WORKMANSHIP STANDARD PER WI 751-001

UNLESS OTHERWISE SPECIFIED: ALL DIMENSIONS ARE IN INCHES

WEIGHT: 604.258 LBS.

	NAME	DATE
DRAWN	TLC	3/4/2021
CHECKED	AC	3/4/2021
APPROVED	TAC	3/4/2021



**THE SUBSEA COMPANY INC**

SIZE	TITLE:	REV
<b>B</b>	BOP FILTRATION PANEL WITH UV	<b>A1</b>

DWG. NO. TSC-02264-GA

SHEET 1 OF 1