

REVISIONS				
REV.	DESCRIPTION	ECO #	DATE	APPROVED
A1	RELEASE	2014-451	10/10/2014	GMB

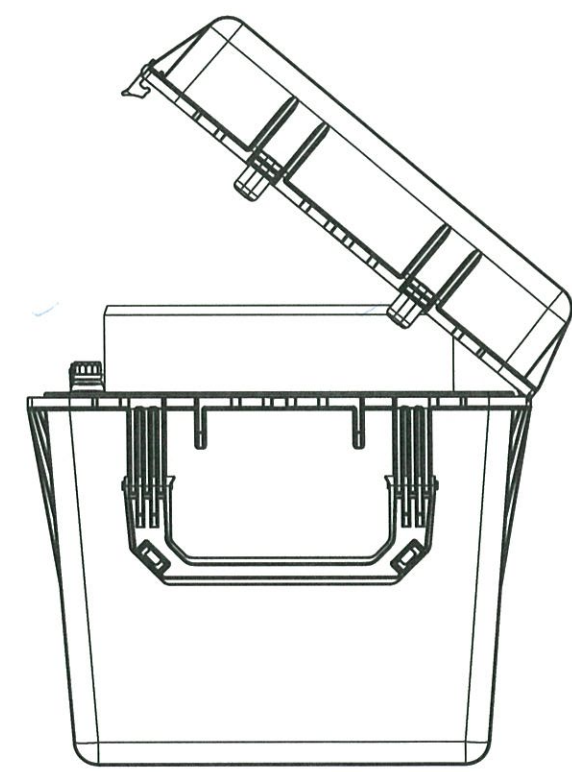
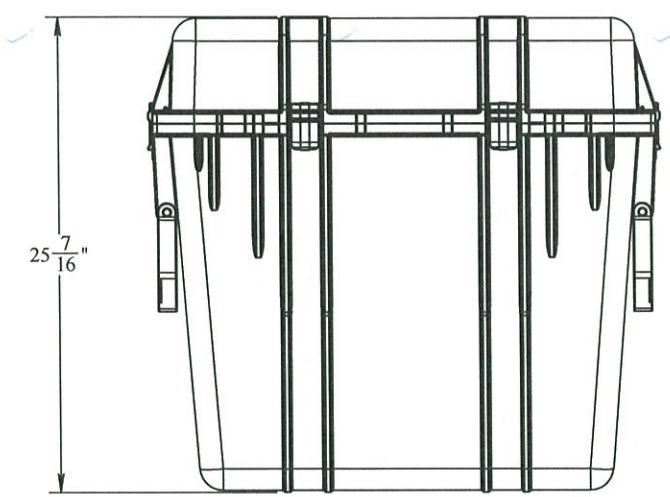
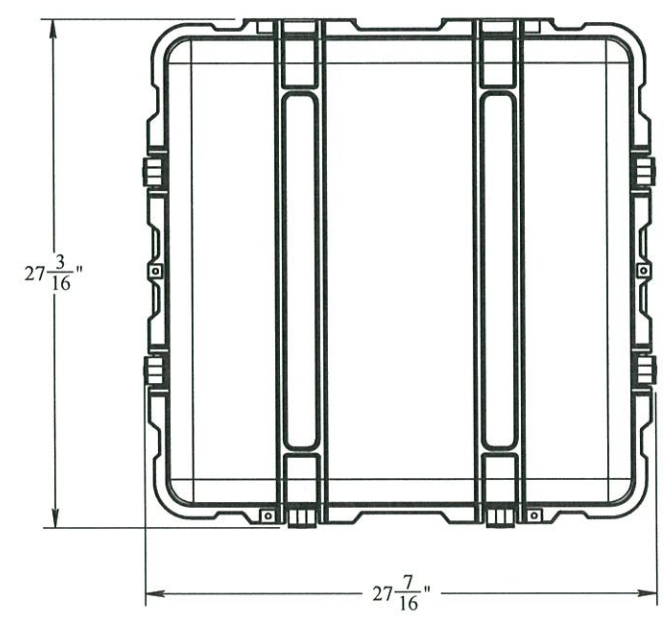

**DRIFT FEATURES**

1. OUTSIDE DIAMETER 18.720 +.010-.000 IAW API 16A
2. PAD EYE - BOTH ENDS
3. WORKING LOAD 3,000 LBS.
4. PULL TESTED TO 4,500 LBS.
5. APPROX. WEIGHT: 301 LBS.
6. MILD STEEL CONSTRUCTION (36 KSI)
7. DESIGNED TO THE SUBSEA COMPANY STANDARD QUALITY PLAN
8. DRIFT IS DESIGNED FOR SURFACE TESTING ONLY

**CASE FEATURES**

9. CONVENIENT SHIPPING & STORAGE CONTAINER FOR DRIFT.
10. DESIGNED SPECIFICALLY FOR THE 18-3/4" x 23" DRIFT.
11. INTERNAL 4 LB. FOAM STRUCTURE PREFIT FOR THE DRIFT.
12. POCKETS FOR DATABOOK & OIL BOTTLE.
13. INCLUDES SET OF 4 CASTERS.

**PROPRIETARY AND CONFIDENTIAL:**  
 THE INFORMATION CONTAINED IN THIS DRAWING IS THE SOLE PROPERTY OF THE SUBSEA COMPANY INC. ANY REPRODUCTION IN PART OR AS A WHOLE WITHOUT THE WRITTEN PERMISSION OF THE SUBSEA COMPANY INC IS PROHIBITED.

WORKMANSHIP STANDARD PER WI 751-001

UNLESS OTHERWISE SPECIFIED: ALL DIMENSIONS ARE IN INCHES

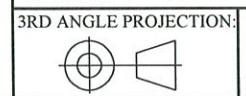

INTERPRET GEOMETRIC TOLERANCING PER: ASME Y14.5

	NAME	DATE
DRAWN	GMB	10/10/14
CHECKED	LDK	10-13-14
Q.A.		10/13/14
MFG./SALES	Trent	10-13-14

		THE SUBSEA COMPANY INC	
		SIZE <b>B</b>	TITLE: DRIFT ASSEMBLY 18 3/4" API, 23" WITH PAD EYES
DWG. NO.	TSC-02106-GA	REV	<b>A1</b>
		SHEET 1 OF 1	